

TOWNSHIP OF O'HARA
COUNCIL REGULAR MEETING
APRIL 9, 2024
AGENDA
7:00 P.M.

(a) – denotes attachment

I. Opening Procedures

- A. Call to Order
- B. Pledge of Allegiance
- C. Roll Call

II. Visitor

- A. Mark Rothert, Executive Director of Lauri Ann West Community Center

The consensus of Council during the March 12th meeting was to ask the Executive Director of the Community Center to attend a meeting to discuss community access and involvement at the Community Center.

III. Minutes

- A. Council Workshop – March 5, 2024
- B. Council Public Hearing – March 12, 2024
- C. Council Regular Meeting – March 12, 2024

A motion will be needed to approve the subject Minutes, followed by a second to the motion and a **voice vote**.

IV. Finance

- A. Vouchers – March 2024 (a)

A motion will be needed to approve the subject Vouchers, followed by a second to the motion and a **voice vote**.

- B. Receipts and Expenditures Records – January and February 2024 (a)

The January Receipts and Expenditures Records were not approved in March since the audit was not yet completed. The audit has since been completed. A motion will be needed to accept the subject Receipts and Expenditures Records, followed by a second to the motion and a **voice vote**.

- C. Treasurer's Report

The Township Treasurer will give a brief report concerning the status of the Township's finances.

V. Reports

A. Other Organizations and Agencies Reports

Individual Council members may have reports for the rest of Council and audience concerning certain organizations and agencies (North Hills COG, etc.).

B. Monthly Departmental Reports

Council may have questions or comments concerning the written monthly reports at this time.

C. Manager's Report

Council may have questions or comments concerning the Manager's written monthly report at this time, or the Manager may have additional information to report.

VI. Old Business

A. Ordinance – Second Reading and Adoption

- (1) B-12-2024: Repealing and Restating the Township Civil Service Commission Rules and Regulations (a)

The Township Civil Service Commission has reviewed the Rules and Regulations and has offered recommendations to expedite the process to create an Eligibility List and modernize the regulations. If acceptable, a motion will be needed to adopt the attached proposed ordinance Bill No. B-12-2024 followed by a second to the motion and a **roll call vote**.

VII. New Business

A. Proclamation

- (1) Recognizing Local Government (a)

Part of the requirements for the Township to be considered a "Banner Community" include promoting local government. The Township provides for the health, safety, and welfare of the general public, as well as educational programs, including but not limited to preserving the ecosystem, storm water management, and recycling. Township staff and Councilmembers communicate openly with Township residents through traditional means and social media. If acceptable, a motion will be needed to approve the attached proposed Proclamation, followed by a second to the motion and a **voice vote**.

B. Resolutions

- (1) B-17-2024: Granting Final Land Development Approval to the Center for Organ Recovery and Education (C.O.R.E.) (a)

It has been proposed by C.O.R.E., owner of parcel 226-M-80 located along Kappa Drive, to construct a 2-story building with parking accommodation, driveways, landscaping,

lighting and stormwater management controls. The lot is in the SM Suburban Manufacturing District. The Township Planning Commission completed its review of the Plan at its March 18th meeting and has recommended to Council that approval be granted subject to the conditions noted in the attached proposed resolution. If acceptable, a motion will be needed to approve the attached proposed resolution Bill No B-17-2024 followed by a second to the motion and a **roll call vote**.

- (2) B-18-2024: Awarding a Contract for the 2024 Road Improvement Program with Fox Chapel Borough (a)

Township Engineer Chuck Steinert is recommending awarding a contract for the 2024 Road Improvement Program to Youngblood Paving in the amount of \$721,422.30 for the base bid and \$455,658.20 for the selected alternates for a total contract amount of \$1,177,080.50. The 2024 Township budget provides an allocation of \$1,300,000 for the program. The contract includes milling and resurfacing Alpha, Glengary, Woodland, Orchard Hill Drives, Field Club Ridge Road and Ravine Street. The alternates include a portion of River Road beyond the Miramar Landings development, Greyfriar, Kirkwall, Berwick Drives and Kerrwood Road, pedway rumble strips on Kappa and Zeta Drives. The pickleball court at Meadow Park will also be paved at a cost of \$96,187.60, which will be partially reimbursed by a grant. If acceptable, a motion will be needed to approve the attached proposed resolution Bill No. B-18-2024 followed by a second to the motion and a **roll call vote**.

- (3) B-19-2024: Accepting the Spring Commodities Bids Received by the South Hills Council of Governments Purchasing Alliance (a)

The South Hills Area Council of Governments opened bids received for its spring commodities contracts on March 7th. Attached is the bid tabulations. Staff is requesting authorization to accept the bids to secure the quoted prices on an as-needed basis. If acceptable, a motion will be needed to approve the attached proposed resolution Bill No. B-19-2024 followed by a second to the motion and a **roll call vote**.

VIII. Citizens Comments Concerning Non-Agenda Items

IX. Other Business

- A. Discussion of Request for Letter of Support from Cooper Siegel Library Regarding Grant Application

Jill McConnell, Executive Director of the Cooper Siegel Library, has requested a letter of support for a grant application with Pennsylvania Department of Community and Economic Development under the COVID-19 ARPA Capital Projects Fund Multi-Purpose Community Facilities Program. The purpose for requesting grant funds is to expand access to broadband connectivity to support education, health, and work initiatives at the library. The Township, in partnership with the Lauri Ann West Community Center, is also applying for the same grant for the community center expansion project. Staff is requesting guidance from Council.

B. Update on Discussions with Blawnox Police Department About Combining Police Departments

Township staff and Blawnox Borough staff met to further discuss the possibility of combining the Blawnox Police Department under the Township of O'Hara Police Department. Staff will provide a verbal update for Council.

C. Update on Discussion Among O'Hara Fire Departments and Blawnox Volunteer Fire Company About Joint Recruiting, Retention, Training and Capital Purchasing

Representatives from both municipalities and fire departments met to discuss joint training, purchasing and recruitment. Staff will provide a verbal update for Council.

D. Veteran's Fish Rodeo – May 8, 2024

Once again, the Morningside VFW will be sponsoring the Twelfth Annual Fish Rodeo at O'Hara Township Community Park on May 8th beginning at 11:00 a.m.

E. Solicitor's March 10, 2024 Invoice

Council was provided with a copy of the subject invoice for review.

X. Concerns of Council

XI. Concerns of Staff

XII. Adjournment

XIII. Executive Session – Labor and Legal Matters

TOWNSHIP OF O'HARA
ALLEGHENY COUNTY, PENNSYLVANIA

AN ORDINANCE OF THE TOWNSHIP OF O'HARA REPEALING AND
RESTATING ORDINANCE NO. 1407 IN ITS ENTIRETY AND
ESTABLISHING NEW RULES AND REGULATIONS FOR THE
TOWNSHIP CIVIL SERVICE COMMISSION

WHEREAS, the Township Council established the O'Hara Township Civil Service Commission pursuant to Article XIV, Section 1402 of the Home Rule Charter; and

WHEREAS, the Civil Service Commission is charged with the powers and duties to prepare policies, procedures and regulations of the personnel system; and

WHEREAS, the Council, upon recommendation of the Township Civil Service Commission, is desirous of repealing and restating Ordinance No. 1407 in its entirety and establishing new Rules and Regulations for the Township Civil Service Commission.

NOW, THEREFORE, the O'Hara Township Council hereby ordains that Ordinance No. 1407 and all amendments thereto are hereby repealed in its entirety and restated in New Civil Service Commission Rules and Regulations are adopted as attached hereto.

ORDAINED this ____ day of _____, 2024 by Council vote of ____ to ____.

ATTEST:

TOWNSHIP OF O'HARA

Julie A. Jakubec, CPA, CGMA
Township Manager

Cassandra R. Eccles
President of Council

First Reading	<u>Hughes - Stewart</u>	<u>5 - 0</u>	<u>03/12/2024</u>
Second Reading & Adoption	_____	_____	_____
Advertised	_____	Codified	_____

**TOWNSHIP OF O'HARA
CIVIL SERVICE
COMMISSION RULES AND
REGULATIONS AMENDED
AND RESTATED
AS OF
MARCH 2024**

PROPOSED - 4/9/2024

Section 1. Definition of Terms

Unless otherwise expressly stated, the following words and phrases, where used in these Rules and Regulations, shall be construed to have the meaning indicated herein:

- A. **Applicant** - Any individual who properly, fully and accurately completes an application in a timely manner and files the same with the Commission in response to a legally advertised notice of vacancy and/or examination for any advertised Police Officer position in the Police Department.
- B. **Appointing Authority** - The Township Manager of the Township of O'Hara of Allegheny County, Pennsylvania.
- C. **Background Investigation** – Verification of information by an outside agency and/or the Superintendent of Police or their designee on job application or statements made to Civil Service Commission or Township which includes, but is not limited to, credit history, record of criminal convictions, review of employment information and separation records consistent with Title 44, Chapter 73 Law Enforcement Background Investigations and Employment Information, and interviews with family members, acquaintances, neighbors, references, teachers, school officials and employers. The Background Investigation is done as a condition of selection.
- D. **Certification** – Upon the Appointing Authority's request, the submission of three names taken from the Eligibility List developed by the Civil Service Commission.
- E. **Chairperson** - The Chairperson of the Civil Service Commission of the Township of O'Hara of Allegheny County, Pennsylvania.
- F. **Commission** - The Civil Service Commission of the Township of O'Hara, Allegheny County, Pennsylvania.
- G. **Council** - The governing body of the Township consisting of 7 elected members, or such other composition as determined by the Home Rule Charter.
- H. **Eligible** - A person whose name is recorded on a current Eligibility List or furlough list.
- I. **Eligibility List** - The list of names of persons who have passed all examinations, ranked in numerical order for a particular position or positions in the Police Department.
- J. **Examinations** - The series of tests given to applicants to determine their qualifications for a position or positions in the Police Department.
- K. **Furlough List** - The list containing the names of persons temporarily laid off from positions in the Police Department because of a reduction in the number of officers.
- L. **Gender** - The Township endeavors to use inclusive language. The masculine, feminine and nonbinary pronouns used herein shall include the masculine, feminine and nonbinary genders.
- M. **Manager** - The Manager of the Township of O'Hara, Allegheny County, Pennsylvania.
- N. **Medical Examinations** - Any examination, procedure, inquiry, or test designed to obtain information about medical history or a physical or mental condition which might disqualify an applicant if it would prevent the applicant from performing, with or without a reasonable accommodation, the essential functions of the position. Whenever referenced this term shall include, but is not limited to, physical, hearing, vision, drug and alcohol, and psychological examinations or tests.

- O. Oral Examination Board** – A group of three (3) professional individuals independent of the Commission and Township with law enforcement or relevant experience as determined by the Commission, appointed to administer an oral proficiency examination.
- P. Police Officer** - For purposes of these Rules and Regulations, an entry level sworn position in a Police Department as a law enforcement officer.
- Q. Polygraph Examination** - An examination intended to detect and record changes in physiological characteristics, such as a person's pulse and breathing rates, used especially as a lie detector.
- R. Preliminary Background Check** – An initial review of criminal history and driver record that occurs early in the hiring process to determine if there are disqualifying criminal history and driver's license issues.
- S. Probationer** - An Officer in the Police Department who has been appointed from an Eligibility List or who has been appointed or promoted to an advanced position, but who has not yet completed the work-test period of one year.
- T. Reduction in Rank** - A change to a different position or rank where the employee fulfilled all of the requirements of these Rules and Regulations for both the prior and current position or rank. However, a decrease in salary without a change to a different position or rank shall not necessarily constitute a reduction in rank.
- U. Removal** - The permanent separation of a Police Officer from the Police Department.
- V. Residence** - The legal residence of an individual shall be constructed as the place or locality where that individual has evidenced to make a permanent home or principal place of residence and domicile.
- W. Separation Record** - Records required to be maintained under 44 Pa C.S.A. §7308, including employment information required to be maintained by law and:
- (1) Records of the reason or reasons for, and circumstances surrounding, a separation of service for a law enforcement officer on a form developed by the Commission and made available on the Township's publicly accessible Internet website.
 - (2) Records of all criminal charges filed against a law enforcement officer.
 - (3) Records of all civil or ethical complaints made against a law enforcement officer.
 - (4) Records of the disposition of all charges and complaints, including final and binding disciplinary actions, taken by the law enforcement agency against a law enforcement officer, including imposition of probationary or other conditions related to employment.
- X. Soldier** – An applicant honorably discharged from military service in: 1) the armed forces of the United States, or in any women's organization officially connected therewith, during any war or armed conflict in which the United States engaged, 2) or the armed forces of the United States, or in any women's organization officially connected therewith, since July 27, 1953, including service in Vietnam; or 3) the National Guard or Reserves.
- Y. Secretary** - The Secretary of the Civil Service Commission of the Township of O'Hara, Allegheny County, Pennsylvania.
- Z. Suspension** - The temporary separation of a Police Officer from the Police Department.

Section 2. The Commission

2.1 Civil Service Commission

The Commission shall consist of five Commissioners who shall serve without compensation. Council shall endeavor to appoint one member from each of the five wards of the Township. The terms of office shall be four years. The Council shall within thirty (30) days of a vacancy in an unexpired term fill the vacancy by appointment for the remainder of the term.

Each member of the Commission, before entering upon the discharge of the duties of their office, shall take an oath or affirmation consistent with 53 Pa.C.S.A. § 1141 to support the Constitution of the United States and of the Commonwealth of Pennsylvania and to perform their official duties with fidelity.

2.2 Offices Incompatible with Civil Service Commission

No member of the Civil Service Commission shall hold an elective or appointed office in the Township or be an employee of the Township. No member shall be a member of a local, state or national committee of a political party or be an officer in any partisan political club or organization.

2.3 Organization of Commission; Reorganization; Quorum

The Commission shall reorganize the first Monday of January of each even numbered year and shall elect one of its members as its Chairperson, one as its Vice-Chairperson, and one as the Secretary. Three members of the Commission shall constitute a quorum and no action of the Commission shall be valid unless it shall have the concurrence of at least three members.

2.4 Duties of Chairperson

The Chairperson, or in their absence, the Vice-Chairperson, shall preside at all meetings and hearings of the Commission, decide all points of order or procedure and perform any duties required by law or these Rules and Regulations.

2.4.1 Duties of the Vice Chairperson

The Vice Chairperson shall act in the absence of the Chairperson in carrying out the duties of the Chairperson and perform all duties required by law, including these rules and regulations.

2.5 Duties of Secretary

The Secretary or the Commission's designee shall carry on at the direction of the Commission all official correspondence of the Commission, send out all notices required by law and these Rules and Regulations, keep a record of each examination or other official action of the Commission, and perform all other duties required by law or these Rules and Regulations.

2.6 Minutes and Records

The Commission shall keep minutes of its proceedings and records of examinations and other official action. All records of the Commission shall be preserved and disposed of according to the most recent Retention and Disposition Schedule for Records of Pennsylvania Municipalities issued by the Local Government Records Committee under the authority of the Municipal Records Act, 1996, P.L. 1158 No. 177, 53 Pa C.S.A. § 1381 et seq. All records shall not be permitted to leave the Township Office.

The Secretary shall keep minutes of its proceedings showing the vote of each member upon each question. If the member is absent, or fails to vote, or abstains from voting, the Secretary shall indicate the reason for the absence or failure to vote or abstaining from voting in the minutes.

The Commission shall comply with 44 Pa. C.S.A §7308 relating to the maintenance of records of the reason or reasons for and circumstances surrounding a separation of service for a law enforcement officer; records of civil or ethical complaints made against an Officer, and records of the disposition of all charges and complaints, including final and binding disciplinary actions. In addition, the Commission shall cooperate with the Township in the submission of any records resulting from its work to the Municipal Police Officer Education and Training Commission.

Records involving personnel or that are generated or received in compliance with 44 Pa C.S.A §7301 et seq. may not be accessible to the public through the Pennsylvania Right to Know Law. All such requests must be reported immediately to the Township Manager.

2.7 Meetings

Except for the annual organization meeting, all meetings shall be held either at the call of the Chairperson or at the call of three members of the Commission. Subject to any legal requirements, in particular the Sunshine Law, 65 P.S. §701 et seq., (the "Sunshine Law") the Commission shall have the discretion to determine the conduct of its meetings. Meetings, including notice of the same, will be conducted in accordance with the Sunshine Law, 65 Pa C.S.A. §701 et seq.

2.8 Order of Business

Subject to revisions from the Chairperson, the order of business of all meetings of the Commission shall be as follows:

- A. Call to Order/Opening Thought
- B. Roll Call/Quorum Check
- C. Public Comment
- D. Approval of Minutes of Previous Meeting
- E. Unfinished Business
- F. New Business
- G. Date of Next Meeting
- H. Adjourn
- I. Executive Session, if called

2.9 Clerks and Supplies

The Council shall furnish the Commission with such supplies and clerical assistance as may be necessary for the Commission to fulfill its duties. In addition, after consultation with the Township Manager, the Commission may retain counsel, any other consultants or experts, including physicians and psychiatrists, as are necessary. The elected and appointed officials of the Township of O'Hara shall assist the Commission with all reasonable and appropriate efforts in carrying out of the Commission's duties.

2.10 Amendment of Rules and Regulations/Forms

The Commission may recommend to amend, revise, void or replace these Rules and Regulations for any reason by action of a majority of the Commission at any properly convened meeting of the Commission. Before any of the foregoing proposed changes to these Rules and Regulations become effective, these proposed changes must be approved by the Township of O'Hara Council, which can approve with or without amendment. The Commission may amend, revise, void or replace the Forms within the Rules and Regulations without approval of the Township of O'Hara Council, however, they shall be reviewed by the Township Manager and Solicitor in order to conform to the laws of the Commonwealth of Pennsylvania and the Township. Council may order any appropriate changes to said Rules and Regulations or forms as it deems appropriate. These Rules and Regulations, and any amendments thereto shall be made available to the public for distribution or inspection.

2.11 Investigations

The Commission shall have the power to make investigations concerning all matters relating to the administration and enforcement of these Rules and Regulations. The Chairperson of the Commission is authorized to administer oaths and affirmations in connection with such investigations.

2.12 Subpoenas

The Commission shall have the power to issue subpoenas over the signature of the Chairperson, or designee, to require the attendance of witnesses and the production of records and papers pertaining to any investigation or inquiry. The fees of such witnesses for attendance and travel shall be the same as for witnesses appearing in the courts and shall be paid from appropriations for the incidental expense of the Commission. All officers in public service and employees of the Township of O'Hara shall attend and testify when required to do so by the Commission. If any person shall refuse or neglect to obey any subpoena issued by the Commission upon conviction of such refusal or neglect in a summary proceeding, that person shall be sentenced to pay a fine not to exceed one hundred dollars (\$100), and in default of the payment of such fine and costs shall be imprisoned not to exceed thirty (30) days. If any person shall refuse or neglect to obey any subpoena, the Commission may apply by petition to the Court of Common Pleas of Allegheny County for its subpoena requiring the attendance of such persons before the Commission or the court to testify and to produce any records and paper necessary, and in default thereof shall be held in contempt of court.

2.13 Annual Report

The Commission shall make an annual report to the Township of O'Hara Council containing a brief summary of its work during the year and a full accounting for any expenditure of public monies. The annual report shall be available for public inspection.

Such report shall be provided to the Township of O'Hara Council on or before the 31st day of January of each year. The report shall not reference the record of any hearing on a dismissal or reduction where such charges have been dismissed.

2.14 Appointment of Examiners.

The Commission shall appoint experienced written examination, oral examination administrators and physical agility examination administrators to conduct appropriate examinations required by these rules and regulations. The Township shall have the responsibility to appoint the physical and psychological examiners, as outlined in these rules and regulations.

Section 3. Application and Qualifications

3.1 Outline of Process

The following process shall be followed in selecting a Police Officer:

- A. Complete an application
- B. Complete personal history statement
- C. Pass the physical agility test
- D. Pass the written evaluation with a score of at least 75 percent
- E. Acquire Act 120 Certification prior to oral evaluation
- F. Pass the oral examination with a score of at least 80 percent
- G. Total Scores calculated and ranked, including Veterans Preference, if applicable. Top three applicants will be subjected to a preliminary background check, including a criminal history and driver's license checks. Any applicant eliminated by the preliminary background check will be advised by letter. If an applicant is eliminated the next applicant on the Eligibility List will be added to the top three and a preliminary background check will be conducted. The process will continue until there are top three applicants certified by the Commission.
- H. Presentation of List of top three applicants by Commission to Township Manager
- I. Tentative selection of applicant by Township Manager subject to conditional offer of employment.
- J. Conditional offers shall include:
 - 1) Full background investigation; and
 - 2) Medical and psychological examinations; and
 - 3) Drug and alcohol tests; and
 - 4) Polygraph examination.

The order of conditions for selection will be determined by the Township based on efficiency and effective use of resources.

Upon receipt of satisfactory results from all conditions of the offer, the applicant's appointment to the position occurs with start date as established by the Township Manager.

3.2 Eligibility for Examination

In order to be eligible for participation in any examination for any position with the Police Department, every applicant must submit a completed application form and a signed personal history statement to the Commission, or its designee, before the application deadline stated by the Commission. The application form is currently Form 2017-30, as said Form may be modified from time to time. An incomplete or inaccurate or misleading application will be cause for rejection. Exceptions to the deadline shall be made only for the Act 120 examination and certification that the applicant meets all the requirements for Act 120 except current employment as a Police Officer, which documentation shall be filed no later than the date of the oral examination. In order to assure an appropriate number of interested applicants who meet the basic professional qualifications, applications will normally be encouraged without geographic restrictions.

3.3 Discrimination

The Township of O'Hara is an equal opportunity employer. It is the Township of O'Hara's and the Commission's policy to grant employment opportunities to qualified persons without regard to race, color, sex (gender, gender fluidity, sexual orientation, marital status), national origin, religion, age, except as may be required by law, pregnancy, veteran status, equal pay, disability, or genetic information. The Township of O'Hara and the Commission will provide equal opportunities in all aspects of employment and promotion.

3.4 Availability

Application forms shall be available to all interested persons from the Township Manager in the Township of O'Hara Municipal Building, and from such other offices and officers that the Commission, from time to time, may choose to designate.

3.5 Age Requirements

All applicants must have reached their twenty-first (21st) birthday before the deadline for submitting completed applications.

3.6 General Qualifications – All New Applicants

Every applicant for any position in the Police Department who is not already employed by O'Hara Township as a Police Officer shall, at time of appointment, either possess Act 120 Certification or have passed examinations entitling them to be granted Act 120 Certification once employed as a Police Officer, and shall meet the following qualifications:

- A. Possess a diploma from an accredited high school or graduate equivalence diploma; and
- B. Have no fewer than 6240 hours of experience (equivalent to three (3) years of

- experience) as a Police Officer, or
- C. Possess a baccalaureate degree, or
- D. Possess a minimum of an Associate Degree with no fewer than 4160 hours of experience (equivalent to two (2) years of experience) as a Police Officer.

The applicant shall be required to furnish certified transcripts of grades from the last educational institution from which they graduated by the time of a tentative employment offer, sent directly to the Civil Service Commission (not the Police Department) by the institutions. If the applicant is relying upon time employed on a part-time basis as a Police Officer to fulfill the experience requirements, the applicant shall include with their application a record of total hours employed part-time as a Police Officer complete with the dates of employment and the names of all employers for each employment period. In addition, every applicant must be a United States citizen, be physically and mentally fit to perform the full duties of a Police Officer, and, prior to appointment, possess a valid, insurable, motor vehicle operator's license issued by the Commonwealth of Pennsylvania.

3.7 General Qualifications - Applicants for Advanced Positions

In order to be considered for the position of Sergeant or Captain, the applicant must successfully complete the following process:

- A. Pass the written examination with a score of no less than 75 percent
- B. Pass the oral examination with a score of no less than 80 percent
- C. If not already employed by O'Hara Township as a Police Officer, pass the physical agility test.
- D. If not already employed by O'Hara Township as a Police Officer, undergo a background investigation and pass medical, drug and alcohol, psychological and polygraph examinations.

All applicants for advanced positions shall have continuous prior service as a Police Officer for at least 10,400 hours immediately prior to application, 6,240 of which must be with the Township of O'Hara. The applicant must be employed as a Police Officer for all five years.

All applicants for advanced positions shall have satisfactorily completed the in-service training program for Police Officers or have graduated from a recognized police school. All applicants must have a current Act 120 certification.

Applicants for the position of Sergeant shall be comprised exclusively from non-probationary Police Officers then currently serving the Township unless no non-probationary Police Officer applies or no non-probationary Police Officer passes tests with the requisite minimum scores.

Applicants for the position of Captain shall be comprised exclusively from non-probationary Sergeants then currently serving the Township unless no non-probationary Sergeant applies, or no non-probationary Sergeant passes tests with the requisite minimum scores.

In the event there is no eligible applicant for an advanced position among the existing employees of the Township, public advertisement for an advanced position to potential applicants not already

employed by the Township will not be placed without the approval of Council.

3.8 Rejection of Applicant

The Commission may refuse to examine, or, if examined, may refuse to certify as eligible after examination, any applicant who is found to lack any of the minimum qualifications for examination prescribed in these rules and regulations for the particular position for which the applicant has applied. In addition, the Commission may refuse to examine, or if examined, may refuse to certify any applicant who is:

- A. Found to have omitted, furnished incomplete, inaccurate, misleading or false information on the official application or in response to any portion of the hiring process;
- B. Physically unfit for the performance of the duties of the position of which the applicant seeks employment;
- C. Illegally using a controlled substance, as defined in section 102 of the Controlled Substance Act (Public Law 91-513, 12 U.S.C. § 802) and have not used marijuana for a minimum of five years prior to any Police Officer appointment.
- D. Guilty of any crime involving moral turpitude, or of infamous or notoriously disgraceful conduct, or who has been dismissed from public service for delinquency or misconduct of office;
- E. Affiliated with any group whose policies or activities are subversive to the forms of government set forth in the constitution and laws of the United States and the Commonwealth of Pennsylvania; or
- F. Found to have been suspended, removed, or reduced in rank in any prior or current position due to inefficiency, neglect, intemperance, disobedience of orders, or conduct unbecoming an Officer.

3.9 Recording and Filing Applications

- A. Applications for positions in the Police Department shall be received at the Township of O'Hara Municipal Building only after being properly advertised and before the deadline for receiving applications which must be set forth in the public advertisement. (Form 2017-10 Public Advertisement) Applications will be received by the municipal officer designated in the public advertisement or that officer's designee. That person shall record the receipt of all applications and provide each applicant with Form 2017-20, Information for Applicants, which shall outline the sequence for all portions of the testing procedure beginning with the physical agility examination. Any application containing errors or omissions may, at the discretion of the Commission, be returned to the applicant for correction prior to the deadline for filing applications after which no new applications or amended applications will be accepted.
- B. Penalty for False Statement - The statements made by the applicant in the official application shall contain no falsification, omission or concealment of fact. Should investigation disclose any willful misstatement, falsification or concealment with respect to an application:
 - 1) The application shall be invalid and the applicant shall be disqualified from

- examination; or
- 2) If the applicant has been examined, the name of such applicant shall be removed from the Eligibility List; or
- 3) If the applicant has been appointed, the applicant shall be discharged.

No person who makes any willful false application shall be permitted to make any future application for any position in the Police Department or the Township.

3.7 Hearing for Disqualified Applicants

Any applicant or person who is aggrieved by the refusal of the Commission to examine or to certify the applicant as eligible after examination, may request a hearing before the Commission. Within ten (10) days after such request, the Commission shall designate a time and place for the hearing which shall be conducted pursuant to the procedures set forth in the Local Agency Law, 2 PA Cons. Stat. § 101 et seq. The applicant or aggrieved party must make their request for a hearing in writing within ten (10) calendar days of the date when the party knew or should have known of the Commission's action which is being challenged. The Commission shall take testimony and review its refusal to provide examination or certification. The Commission shall subpoena, at expense of applicant, any competent witnesses requested by applicant. Following the public hearing, the Commission shall file the testimony taken in its records and shall again make a decision, which decision shall be final.

3.8 Public Notice (The following shall be done at a minimum); Notices

The Commission shall conspicuously post in the Township of O'Hara Municipal Building notice of the time and place of every examination, together with the information as to the type of position to be filled, the requirements for that position, where applications may be obtained for the examination, and the deadline for filing those applications. In addition, at least two (2) weeks prior to each examination, publication of the notice shall occur in at least one (1) newspaper of general circulation, or a newspaper circulated generally in the Township of O'Hara. Where an advanced position is to be filled through promotion of an existing employee, no newspaper notification is required.

Section 4. Examination and Grading Procedure

4.1 General Examination Requirements for the Position of Police Officer

The examination for Police Officer will consist of written and oral examinations which will be graded on a one hundred (100) point scale with the written examination representing forty percent (40%) of the final score and the oral examination representing sixty percent (60%) of the final score. In addition, each applicant will undergo a physical agility test which will be evaluated on a pass/fail basis for every applicant. The top three (3) applicants will undergo a preliminary background check. After an applicant has been extended an offer of employment, final appointment shall be contingent upon the applicant passing medical and psychological examinations, full background investigation, and a polygraph examination.

4.2 General Examination Requirements for Advanced Positions, Except Superintendent

The examination for the positions of Sergeant and Captain shall include both a written and an oral

examination, each of which will be graded on a one hundred (100) point scale. The written examination shall represent forty percent (40%) of the final score and the oral examination shall represent sixty percent (60%) of the final score. All required tests shall be passed in order for the applicant to continue further in the process. All tests shall be practical in character and shall test fairly the merit and fitness of persons seeking promotion (53 P.S. § 55642). In addition, standards set forth in Section 3.7 of these Rules and Regulations shall apply to applicants for the position of Sergeant or Captain. After an applicant who is *not already an employee* has been extended the offer of the advanced position, the final appointment to the promotional position shall be conditioned upon a background investigation, medical, psychological, drug, alcohol, and polygraph examinations. Veterans' preference (points or otherwise) shall not be provided for advanced positions.

4.3 Notice of Examination

The Commission shall appoint a physical fitness examiner, a written examination administrator, an Oral Examination Board, a medical examiner, a psychological examiner, and a polygrapher to conduct the appropriate examinations required by these Rules and Regulations.

4.4 Written Examinations

The written examination shall be graded on a 100-point scale and an applicant must score seventy-five percent (75%) in order to continue in the application process. Applicants scoring less than seventy-five percent (75%) shall be rejected. Upon receipt of the test results, all applicants shall be given written notice in accordance with Section 4.9 of these Rules and Regulations, of their test results. Only the top twelve (12) applicants with scores of seventy-five percent (75%) or higher shall be scheduled for an oral examination appointment.

4.5 Oral Examination

The top twelve (12) applicants who score seventy-five percent (75%) or higher in the written examination shall be given an oral examination which will be graded on a one hundred (100) point scale with a score of eighty percent (80%) or higher necessary for passing. The oral examination shall involve questioning applicants on how they would handle situations relevant to police work. Each applicant will be asked essentially the same questions, in the same order, and advised that the interview will be recorded and will be confidential. The oral examination will be conducted by the Oral Examination Board.

4.6 Veterans Preference

Where required by law, any applicant for the position of Police Officer who qualifies as a Soldier under the Veterans Preference Act, 51 P.S. §7101.1, shall receive an additional ten (10) points on top of their total score if that applicant had received passing scores under Sections 4.1, 4.4 and 4.5.

Applicants claiming veteran's preference shall have submitted satisfactory proof of service and honorable discharge therefrom with their application form.

4.7 Physical Agility Testing

Applicants for the position of Police Officer shall meet the requirements of the physical agility test

before proceeding to the written and oral examinations. Requirements of the physical agility test will be provided in the Information to Applicant received with the Application Form.

Applicants will be informed of their pass/fail status upon completion of the Physical Agility Test. Applicants that successfully complete the Physical Agility Test will proceed directly to the written examination.

4.8 Background Investigation

A Preliminary Background Check is performed on the top three scoring applicants and shall include a criminal history and driver's license check to determine if there are any disqualifying violations. A Full Background Investigation will be conducted on any conditionally selected applicant. The background investigation may include interviews with the applicant's family, acquaintances, current and former neighbors, references, current and former teachers, school officials and employers. In addition, the applicant's credit history and record of criminal convictions may be investigated. The applicant may be interviewed directly when the information collected during the background investigation requires clarification or explanation.

After the Background Investigation is completed, investigator(s) shall make a written recommendation to the Commission on whether the applicant is appropriate for consideration for the appointment as a Police Officer. If the recommendation is to disqualify, then a detailed written explanation of the reasons for disqualification must be included. The Commission shall make the final determination on whether the information collected during the preliminary background check warrants rejection of the applicant.

Disqualification of any applicant shall be done in writing in accordance with Section 4.9 of these Rules and Regulations, and shall include the procedure to follow to appeal the decision that the applicant must request in writing a hearing before the Township of O'Hara Civil Service Commission within ten (10) days of receipt of the notice of disqualification.

Disqualifications will be done in accordance with all applicable laws.

4.9 Communication/Notification

All communication/notification between the applicants and Township shall be via First Class Mail and/or email, and/or other efficient means. The communication/notification includes, but is not limited to, examination/testing dates, time, location; pass/fail status of examinations/tests.

The Township Manager, or other designated person, shall give, in writing, to each applicant qualified for the next step in the examination process, a notice which shall include the date, time and place the applicant shall report for the next examination in the process. In the case of physical and psychological examinations, the Township Manager shall notify the Police Officer applicant who has been conditionally offered a position in the police department by a written notice of the date, time and place of the examinations as well as the name of the physical and psychological examiners.

Every such notice shall be emailed or otherwise delivered at least seven (7) days prior to the date fixed for examination. Only applicants receiving notices to report for any examination shall be permitted to participate in such examination, and each applicant shall present the notice to the

examiner before the examination. Failure to report for an examination in accordance with the instructions contained in the written notice shall disqualify the applicant, except that in the case of a physical or psychological examination, the physician or psychologist designated in the notice may fix another date or time for such examination, provided, however, that any such date or time shall be written with the period of at least seven (7) days of the date and time established in the written notice.

4.10 Tie Breaker

In the event there is a tie of the total score, including Veterans Preference Points, the Commission will have prepared and separately scored a single question in the oral examination. The score of this question shall be the tie breaker between or among applicants with the same total score. The question will be predetermined as the tie breaker prior to the beginning of the selection process and shall not be used for any other purpose than to break a tie between or among applicants with the same total score for purpose of ranking on the Eligibility List. If there is a tie among or between applicants with the same score on the tie breaker question, the applicant with the earliest time of receipt of the application will be the final tie breaker for purpose of ranking on the Eligibility List.

Section 5. Certification of the List of Eligibility and Appointment

5.1 Creation of Eligibility List

At the completion of the physical agility test, written examination and oral examination the Commission shall rank all passing applicants on a list with the applicant receiving the highest score at the top of the list and the applicant receiving the lowest passing score at the bottom of the list. Applicants who qualify for veterans' preference points shall have those points added to their passing score prior to being ranked on the Eligibility List. For promotional positions, fulfilling the performance requirement set forth in Section 3.7 is also required. In the case of tied scores, the tie will be broken by the process outlined in Section 4.10.

The Eligibility List will be valid for eighteen (18) months from the date the Commission formally adopts the Eligibility List. Prior to the expiration of the Eligibility List, the Commission may recommend the extension of the Eligibility List for up to an additional twelve (12) months to Council for approval.

5.2 Appointment

- A. The Township Manager may fill any vacancy in an existing position in the Police Department which occurs as a result of expansion of the police force, retirement, resignation, disability or death by the reappointment or reinstatement of a former employee of the Police Department who has been furloughed. Except for the medical and psychological examinations, no other testing shall be required for a furloughed employee or a rehired or reappointed employee. The Township Manager shall have the discretion, on a case-by-case basis, to decide whether or not a furloughed employee shall be required to take medical and/or psychological examinations before being rehired or reappointed.
- B. All Police Officer positions except those filled by furlough lists and that of

Superintendent of Police, shall be filled only in the following manner:

- 1) The Township Manager shall notify the Commission of any vacancy which is to be filled and shall request the certification of three (3) names from the Eligibility List;
 - 2) If three (3) names are not available, then the Commission shall certify the name(s) remaining on the List;
 - 3) The Township reserves the right to perform additional background and reference verification prior to hiring an eligible applicant;
 - 4) The Township Manager shall make an appointment from one of the three names certified with reference to the merits and fitness of the applicants.
- C. Nothing contained herein shall obligate the Township Manager to make an appointment or shall grant any right to any applicant or member of any Eligibility List to be appointed. The Township has the discretion to reject all applicants certified, to reject specific applicants in accordance with these regulations, or to choose any of the applicants who are in the top three, not necessarily in numerical order, unless there is a Veteran in the top three entitled to selection preference. If all applicants in the top three are rejected the Township may move down the List once the due process requirements for rejected applicants are met or may start the process over to create a new Eligibility List. If a specific applicant or applicants are rejected from the certified list of three, the Township may request that the Commission certify a new List of three by adding an applicant or applicants from the Eligibility List, until a qualified applicant is selected.

5.3 Appointment of Superintendent of Police

In the case of a vacancy in the office of Superintendent of Police and/or Deputy Superintendent of Police, the Township Manager has full discretion in selecting the individual to fill the position of Superintendent of Police and/or Deputy Superintendent of Police. If the Township Manager requests the Commission to subject that person to a noncompetitive examination, and if that person successfully passes the noncompetitive examination, then the Commission shall notify the Township Manager of the results of the examination and, if appointed, that person may only be removed from the position of Superintendent of Police for the reasons set forth in Section 6.1.

5.4 Physical, Psychological, and Polygraph Examinations

After the Township Manager selects an applicant from the three certified individuals on the Eligibility List for appointment to the vacant position, that applicant shall submit to medical, psychological, drug, alcohol, and polygraph examinations by the appropriate appointed experts.

- A. **Medical:** The conditional appointee must be certified as free from bodily or mental defects, deformity or disease that might incapacitate the applicant from the discharge of the duties of the position desired. A copy of the exact requirements is on file with the Commission. Notwithstanding this, the medical examiner may reject an applicant for any job-related medical reason. If the applicant successfully passes the medical and psychological exams, then the applicant may be appointed to the vacant position in the Police Department for which the application was submitted. If the opinion rendered by the appointed examiner calls into question the conditional appointee's ability to perform

all essential functions of a position, the Township Manager or their designee shall meet with the conditional appointee for the purpose of having one or more interactive discussions on whether the conditional appointee can, with or without reasonable accommodation, perform all the essential functions of the position. If, at the conclusion of the interactive discussion(s) the Township Manager or their designee determines that the conditional appointee cannot perform the essential functions of the job of Police Officer, with or without a reasonable accommodation, the Township Manager shall give written notice to the conditional appointee and the Civil Service Commission, that the conditional offer is revoked and the basis therefore.

- B. Polygraph. Each conditional appointee shall undergo a polygraph examination to test the truthfulness of the information provided during the application process and for good moral character. Based on the results provided by the polygrapher, the Township Manager has discretion to reject an applicant who fails the polygraph, have the applicant retested, or reject the results.

5.5 Probationary Period

Every successful applicant to an original position with the Police Department shall serve a twelve (12) month probationary period. During the probationary period, a newly hired Officer may only be dismissed for cause for the reasons set forth in Sections 3.6 and 6.1. However, near the end of the twelve (12) month probationary period, if the conduct or fitness of the probationer has not been satisfactory to the Township Manager or their designee, the probationer shall be notified in writing prior to the termination of the probationary period that the appointment will not be permanent. At that time, a newly hired Officer's employment shall end. Any Officer who is not informed in writing within their probationary period that their performance has been unsatisfactory, shall receive a permanent appointment to the new position.

Where an individual who is already a Police Officer for the Township has been promoted to an advanced position, that individual shall serve a twelve (12) month probationary period within that advanced position. During the probationary period, the promoted Officer may be either dismissed for cause or reduced in rank for cause, for the reasons set forth in Sections 3.6., 3.7 and 6.1. However, near the end of the twelve (12) month probationary period, if the conduct or fitness of the probationer has not been satisfactory to the Township Manager or their designee the probationer shall be notified in writing prior to the termination of the probationary period that the appointment will not be permanent. At that time, either the promoted Officer shall be reduced in rank or the promoted Officer's employment shall end. If the promoted Officer is not informed in writing within the probationary period that their performance has been unsatisfactory, they shall receive a permanent appointment to the new position.

Any probationer who is notified in writing that their appointment will not be made permanent may appeal for a hearing before the Civil Service Commission.

Section 6. Suspensions, Removals and Reductions in Rank

6.1 Grounds for Disciplinary Action

- A. No person appointed to a position in the Police Department pursuant to these Rules and

Regulations may be suspended, removed or reduced in rank except for the following reasons:

- 1) Physical or mental disability affecting the Officer's ability to continue in service, in which case the Officer shall receive an honorable discharge from service;
 - 2) Neglect or violation of any official duty;
 - 3) Violation of any law of this Commonwealth which provides that such violation constitutes a misdemeanor or felony;
 - 4) Inefficiency, neglect, intemperance, disobedience of orders or conduct unbecoming of a Police Officer;
 - 5) Intoxication while on duty; or
 - 6) Engaging or participating in conducting any political or election campaign other than the Officer's exercise of the right of suffrage.
- B. No Officer shall be removed for unlawful reason, including but not limited to, religion, race, sex, sexual orientation, sexual identity, or politics.
- C. The Superintendent of Police or the Township Manager may impose more significant discipline because of extenuating circumstances surrounding an incident of misconduct.

6.2 Removal

The Township Manager or a designated representative may suspend a Police Officer without pay pending the determination of any charge or charges, including disabilities, against the person. In the event the Commission fails to uphold the charge or charges then the person sought to be suspended, removed or reduced in rank shall be reinstated with full pay for the period during which the person was suspended, removed or reduced in rank, and no charge or charges shall be officially recorded against the person's record.

6.3 Furloughs

- A. If for reasons of economy or other reasons, it shall be deemed necessary by the Township of O'Hara to reduce the number of Police Officers in the department, then the Township of O'Hara shall apply the following procedure: (1) if there are any employees eligible for retirement under the terms of any retirement or pension law, then such reduction in numbers shall be made by retirement if the party to be retired exceeds the maximum age as defined in the Pennsylvania Human Relations Act; (2) if the number of Police Officers eligible for retirement is insufficient to effect the necessary reductions in numbers, or if there are no persons eligible for retirement, or if no retirement or pension fund exists, then the reductions shall be effected by furloughing the person or persons, including probationers, last appointed to the respective force.
- B. Such removal shall be accomplished by furloughing in numerical order commencing with the person last appointed until such reduction shall have been accomplished. In the event that the Township Manager decides to increase the Police Department, the furloughed Officers shall be reinstated in order of their seniority in the department if the furloughed Officer accepts reinstatement in writing within thirty (30) days of receiving

notice of the opening. These reductions in force provisions are not applicable to the Superintendent of Police.

6.4 Notice of Suspensions, Removal or Reduction in Rank

Whenever a Police Officer is suspended, removed or reduced in rank, the specific charges warranting such actions shall be stated in writing by the Township Manager. The charges shall be stated clearly and in sufficient detail to enable the Officer to understand the charges and to allow the Officer an opportunity to respond to those charges. The charges shall specify the subsection of Section 6.1 which provides the basis for the disciplinary action as well as an explanation of the factual circumstances upon which the Township Manager relied in finding a violation of Section 6.1.

Within five days after the Township Manager has filed written charges, the written charges shall be delivered to the Officer either by personal service or by certified or registered mail. In addition, the Police Officer shall be notified of the right to appeal under Section 6.5 of these Rules and Regulations. A copy of the statement of charges shall also be served upon the members of the Civil Service Commission by regular first-class mail or in person.

6.5 Hearings on Suspension, Removals and Reductions in Rank

The Officer who has been suspended, removed or reduced in rank may appeal the decision of the Township Manager by written notice to the Secretary of the Civil Service Commission at 325 Fox Chapel Road, Pittsburgh, PA 15238 requesting a hearing. This request shall be received by the Commission within ten days after the Officer receives notice of the discipline. The Officer may make written answers to any charges filed not later than the date fixed for the hearing. Failure of the Officer to provide written answers to any of the charges shall not be deemed an admission by the Officer.

- A. The Commission shall schedule a hearing within ten days from the Officer's written request for a hearing unless continued by the Commission for a cause at the request of the Township Manager, or the Officer. At any such hearing, the Officer against whom the charges have been made may be present and represented by counsel, may call witnesses and present testimony and documentation in defense. The Township of O'Hara may also be represented by counsel, call witnesses and present evidence as is necessary to support the charges. A stenographic record of all testimony shall be taken at every hearing and preserved by the Commission. In the event the charges are dismissed, the record shall be sealed and not be available for public inspection.
- B. In conducting the hearing, the Commission's standard of review shall be to determine whether sufficient evidence has been presented to support the statutory reason for the disciplinary action. If the Commission finds that sufficient evidence has been introduced to support the charge, the Commission shall not modify the penalty imposed by the Township Manager unless it finds that the penalty imposed was arbitrary, discriminatory or an abuse of the Manager's discretion. The Commission may request post-hearing briefs and shall issue a written decision containing specific findings of fact and conclusions of law within sixty (60) days of receipt of the hearing transcript.
- C. The standard of review which has been incorporated into these Rules and Regulations is based on Commonwealth Court decisions. See *Jenkintown v. Civil Service*

Commission of Jenkintown, 84 Pa. Cmwlth. 183, 478 A.2d 941 (1984); *Hermann v. Civil Service Commission of Jenkintown*, 84 Pa. Cmwlth, 211, 478 A.2d 961 (1984).

6.6 Hearing Procedure

- A. All testimony shall be given under oath administered by the Chairperson, or in absence of the Chair, the Vice-Chairperson. The Commission shall have power to issue subpoenas as set forth in Section 2.12. The hearing shall be open to the public unless, prior to the commencement of the hearing, a written or oral request to close the hearing is made by either the charged Officer or the Township of O'Hara.
- B. If the Commission sustains the charges, the Officer who was suspended, removed or reduced in rank may file an appeal with the Court of Common Pleas within thirty (30) days from the date of entry by the Commission of its final order. No order of suspension shall be sustained by the Commission for a period longer than one year. In the event the Commission fails to uphold the charges, then the person sought to be suspended, removed or demoted shall be reinstated with full pay for the period of the suspension, removal or demotion, and no charges related to the suspension, removal or reduction in rank shall be officially recorded in the Officer's record.

**OFFICIAL PROCLAMATION
RECOGNIZING LOCAL GOVERNMENT**

PROPOSED – 4/9/2024

WHEREAS, local government is responsible for ensuring the immediate availability of essential services, including, but not limited to, police and fire protection services, emergency medical services; and

WHEREAS, the Township of O'Hara elected officials and staff communicate openly with local residents and the media through email, correspondence, telephone, meetings, Newsletters, Nixle, FaceBook, X and Call Fire to ensure an understanding of existing and potential health and safety issues; and

WHEREAS, the Township of O'Hara has enabled stability in tax revenue by successfully receiving various grant funds for many community projects; and

WHEREAS, the Township of O'Hara and its partners have implemented educational programs focused on preserving the ecosystem, including Municipal Separate Storm Sewer Systems (MS-4), rain barrels and rain gardens, composting, recycling of household products and hazardous household wastes; and

WHEREAS, the Township of O'Hara is an exemplary model for local government as a result of professional staff and valuable contributions made by citizens serving their communities on various Boards, Commissions and Committees.

NOW, THEREFORE, BE IT RESOLVED, that I, Cassandra R. Eccles, President, on behalf of the Township of O'Hara Council, on this day, the ___ day of _____ in the year 2024, do hereby recognize and commend local government efforts which are important to the citizens and the vitality of the community.

*Cassandra R. Eccles
President of Council*

**TOWNSHIP OF O'HARA
ALLEGHENY COUNTY, PENNSYLVANIA**

**A RESOLUTION OF THE TOWNSHIP OF O'HARA GRANTING FINAL
LAND DEVELOPMENT APPROVAL TO THE CENTER FOR ORGAN
RECOVERY AND EDUCATION (C.O.R.E.) LOCATED ALONG KAPPA
DRIVE**

WHEREAS, the Township of O'Hara Planning Commission ("the Planning Commission") concluded its review on March 18, 2024 and has recommended to the Township of O'Hara Council ("Council") that Final Land Development Approval be granted to the Center for Organ Recovery and Education (C.O.R.E.) located along Kappa Drive, subject to six (6) remaining conditions.

NOW, THEREFORE, BE IT RESOLVED that the Township of O'Hara Council hereby grants Final Land Development Approval to the Center for Organ Recovery and Education (C.O.R.E.) Plan subject to the following six (6) remaining conditions:

1. An application for a grading permit shall be submitted prior to construction.
2. Approval of the Erosion & Sedimentation Control Plan by Allegheny County Conservation District.
3. Ownership and maintenance responsibilities shall follow the Stormwater Facility Maintenance Plan, Section IX in the Post Construction Stormwater Management Plan, and the agreement (Appendix B of the Township Stormwater Ordinance) must be executed prior to the start of construction.
4. Copies of all inspections of the stormwater system must be submitted annually to the Township for review.
5. If, at any time, the number of peak trips increases and/or exceeds 50 trips, the Township may require a Traffic Impact Study to be submitted to the Township for review.
6. Approval of the Sewer Planning Module.

NOW, THEREFORE, BE IT FURTHER RESOLVED that Final Land Development Approval does not authorize site development, the construction of buildings or structures unless and until the Plan has been recorded with the Allegheny County Recorder of Deeds as provided in the Township of O'Hara Subdivision and Land Development Ordinance, and the applicant has been issued grading, building, and/or other required permits or approvals.

BILL NO. B-17-2024

RESOLUTION NO. _____

RESOLVED by Council vote of ___ to ___ on this _____ day of _____, 2024.

ATTEST:

TOWNSHIP OF O'HARA

Julie A. Jakubec, CPA, CGMA
Township Manager

Cassandra R. Eccles
President of Council

PROPOSED - 4/9/2024

Approved _____

**TOWNSHIP OF O'HARA
ALLEGHENY COUNTY, PENNSYLVANIA**

**A RESOLUTION OF THE TOWNSHIP OF O'HARA AWARDING A
CONTRACT FOR THE 2024 ROAD IMPROVEMENT PROGRAM**

WHEREAS, the Township of O'Hara is participating in a Joint Road Improvement Program with Fox Chapel Borough; and

WHEREAS, sealed bids for the 2024 Road Improvement Program were received by Fox Chapel Borough and opened on March 18, 2024; and

WHEREAS, Youngblood Paving has been determined to be the lowest responsible bidder meeting the Township's specifications as provided to Fox Chapel Borough for the bidding process.

NOW, THEREFORE, BE IT RESOLVED by the Council of the Township of O'Hara that the bid for the 2024 Road Improvement Program be awarded to Youngblood Paving in the amount of \$721,422.30 for milling and resurfacing Alpha, Glengary, Woodland, Orchard Hill Drives, Field Club Ridge Road and Ravine Street. Alternates include a portion of River Road, Greyfriar, Kirkwall and Berwick Drives, Kerrwood Road, pedway rumble strips on Kappa and Zeta Drives in the amount of \$455,658.20, and the pickleball court at Meadow Park in the amount of \$96,187.60 less reimbursement of \$80,450 by a grant, for a total amount of \$1,192,818.10.

RESOLVED by Council vote of ___ to ___ this _____ day of _____, 2024.

TOWNSHIP OF O'HARA

ATTEST:

Julie A. Jakubec, CPA, CGMA
Township Manager

Cassandra R. Eccles
President of Council

Adopted _____

2023 SPRING COMMODITIES

Bids were opened at 2:00 PM, March 7, 2024 for the following commodities:

- Road Aggregates
- Liquid Asphalt
- Bituminous Surfacing Materials
- Line Painting and Reflective Glass Beads
- Guide Rails and Posts-Components and Installation
- Traffic Signs and Sign Posts
- Thermoplastic Pavement Markings
- Frames, Rings, and Grates-Cast Iron and Steel
- Precast Concrete Inlets and Risers
- Manhole Inserts
- Plastic Pipe
- Swimming Pool Chemicals
- Wastewater Treatment Chemicals
- Fertilizers
- Weed Killer
- Ballfield Mixture
- Top Soil
- Hardwood Bark Mulch
- Wood Carpet
- Mushroom Compost
- Portable Toilet Rental Service



SHACOG PURCHASING ALLIANCE

2024 BID TABULATION - ROAD AGGREGATES

CRUSHED RIVER GRAVEL - - DELIVERED AND DUMPED - PRICE PER TON

Allegheny Valley North COG	A & S Landscaping, Inc.	Amerikohl Aggregates, Inc.	Heidelberg Materials Northeast, LLC	Lindy Paving, Inc.		
MINIMUM TONS FOR DELIVERY	NB	NA (* 37)	0	NB		
Butler County COG	A & S Landscaping, Inc.	Amerikohl Aggregates, Inc.	Heidelberg Materials Northeast, LLC	Lindy Paving, Inc.		
MINIMUM TONS FOR DELIVERY	NB	NA (* 37)	0	NB		
Char-West COG	A & S Landscaping, Inc.	Amerikohl Aggregates, Inc.	Heidelberg Materials Northeast, LLC	Lindy Paving, Inc.		
MINIMUM TONS FOR DELIVERY	NB	NA (* 37)	0	NB		
North Hills COG	A & S Landscaping, Inc.	Amerikohl Aggregates, Inc.	Heidelberg Materials Northeast, LLC	Lindy Paving, Inc.		
MINIMUM TONS FOR DELIVERY	NB	NA (* 37)	0	NB		
Quaker Valley COG	A & S Landscaping, Inc.	Amerikohl Aggregates, Inc.	Heidelberg Materials Northeast, LLC	Lindy Paving, Inc.		
MINIMUM TONS FOR DELIVERY	NB	NA (* 37)	0	NB		
South Hills Area COG	A & S Landscaping, Inc.	Amerikohl Aggregates, Inc.	Heidelberg Materials Northeast, LLC	Lindy Paving, Inc.		
MINIMUM TONS FOR DELIVERY	NB	NA (* 37)	0	NB		
Steel Rivers COG	A & S Landscaping, Inc.	Amerikohl Aggregates, Inc.	Heidelberg Materials Northeast, LLC	Lindy Paving, Inc.		
MINIMUM TONS FOR DELIVERY	NB	NA (* 37)	0	NB		
Turtle Creek Valley COG	A & S Landscaping, Inc.	Amerikohl Aggregates, Inc.	Heidelberg Materials Northeast, LLC	Lindy Paving, Inc.		
MINIMUM TONS FOR DELIVERY	NB	NA (* 37)	0	NB		



SHACOG PURCHASING ALLIANCE

2024 BID TABULATION - ROAD AGGREGATES

CRUSHED RIVER GRAVEL - - DELIVERED AND DUMPED - PRICE PER TON VENDOR NOTES
* 3 - NA
* 7 - NA
* 12 - NA
* 15 - NA
* 18 - NA
* 21 - NA
* 25 - NA
* 29 - NA
* 36 - NA
* 37 - NA



SHACOG PURCHASING ALLIANCE

2024 BID TABULATION - ROAD AGGREGATES

CRUSHED RIVER GRAVEL -- FOB PICKUP BY MUNICIPALITY - PRICE PER TON

Allegheny Valley North COG	A & S Landscaping, Inc.	Amerkohl Aggregates, Inc.	Heidelberg Materials Northeast, LLC	Lindy Paving, Inc.		
MINIMUM TONS FOR PICKUP	NB	NA (* 36)	0	NB		
Butler County COG	A & S Landscaping, Inc.	Amerkohl Aggregates, Inc.	Heidelberg Materials Northeast, LLC	Lindy Paving, Inc.		
MINIMUM TONS FOR PICKUP	NB	NA (* 36)	0	NB		
Char-West COG	A & S Landscaping, Inc.	Amerkohl Aggregates, Inc.	Heidelberg Materials Northeast, LLC	Lindy Paving, Inc.		
MINIMUM TONS FOR PICKUP	NB	NA (* 36)	0	NB		
North Hills COG	A & S Landscaping, Inc.	Amerkohl Aggregates, Inc.	Heidelberg Materials Northeast, LLC	Lindy Paving, Inc.		
MINIMUM TONS FOR PICKUP	NB	NA (* 36)	0	NB		
Quaker Valley COG	A & S Landscaping, Inc.	Amerkohl Aggregates, Inc.	Heidelberg Materials Northeast, LLC	Lindy Paving, Inc.		
MINIMUM TONS FOR PICKUP	NB	NA (* 36)	0	NB		
South Hills Area COG	A & S Landscaping, Inc.	Amerkohl Aggregates, Inc.	Heidelberg Materials Northeast, LLC	Lindy Paving, Inc.		
MINIMUM TONS FOR PICKUP	NB	NA (* 36)	0	NB		
Steel Rivers COG	A & S Landscaping, Inc.	Amerkohl Aggregates, Inc.	Heidelberg Materials Northeast, LLC	Lindy Paving, Inc.		
MINIMUM TONS FOR PICKUP	NB	NA (* 36)	0	NB		
Turtle Creek Valley COG	A & S Landscaping, Inc.	Amerkohl Aggregates, Inc.	Heidelberg Materials Northeast, LLC	Lindy Paving, Inc.		
MINIMUM TONS FOR PICKUP	NB	NA (* 36)	0	NB		



SHACOG PURCHASING ALLIANCE

2024 BID TABULATION - ROAD AGGREGATES

CRUSHED RIVER GRAVEL - - FOB PICKUP BY MUNICIPALITY - PRICE PER TON VENDOR NOTES

- * 3 - NA
- * 7 - NA
- * 12 - NA
- * 15 - NA
- * 18 - NA
- * 21 - NA
- * 25 - NA
- * 29 - NA
- * 36 - NA
- * 37 - NA



SHACOG PURCHASING ALLIANCE

2024 BID TABULATION - ROAD AGGREGATES

LIMESTONE - - DELIVERED AND DUMPED - PRICE PER TON

Allegheny Valley North COG	A & S Landscaping, Inc.	Amerkohl Aggregates, Inc.	Heidelberg Materials Northeast, LLC	Lindy Paving, Inc.			
GABION (4" - 8")	NB	\$31.00 (* 1)	\$35.25	NB			
SIZE NO. 10 (FORMERLY NO 1A)	NB	\$26.00 (* 13)	\$27.75	NB			
SIZE NO. 2A	NB	\$26.00 (* 19)	\$27.90	NB			
SIZE NO. 2RC (FORMERLY 2A MODIFIED)	NB	\$26.00 (* 26)	\$27.90	NB			
SIZE NOS 57, 3 & 1 (FORMERLY 2B, 3A & 4)	NB	\$31.00 (* 33)	\$34.75	NB			
SIZE NO. 67 (FORMERLY 2)	NB	\$31.00 (* 39)	\$35.75	NB			
SIZE NO. 8 (FORMERLY 1B)	NB	\$37.00 (* 42)	\$54.25	NB			
SIZE NO. 8-1% (FORMERLY 1B SEALING)	NB	\$37.00 (* 44)	\$61.25	NB			
SIZE NO. R-3 (RIP-RAP)	NB	\$31.00 (* 46)	\$35.25	NB			
SIZE NO. R-4 (RIP-RAP)	NB	\$31.00 (* 47)	\$37.75	NB			
SIZE NO. R-5 (RIP-RAP)	NB	\$39.88 (* 50)	\$39.75	NB			
SIZE NO. R-6 (RIP-RAP)	NB	\$40.47 (* 51)	\$41.50	NB			
MINIMUM TONS FOR DELIVERY	NB	22 (* 54)	23	NB			



SHACOG PURCHASING ALLIANCE

2024 BID TABULATION - ROAD AGGREGATES - - LIMESTONE - DELIVERED AND DUMPED - PRICE PER TON

Butler County COG	A & S Landscaping, Inc.	Amerkohl Aggregates, Inc.	Heidelberg Materials Northeast, LLC	Lindy Paving, Inc.			
GABION (4" - 8")	NB	\$32.00 (* 1)	NA	NB			
SIZE NO. 10 (FORMERLY NO 1A)	NB	\$27.00 (* 13)	NA	NB			
SIZE NO. 2A	NB	\$27.00 (* 19)	NA	NB			
SIZE NO. 2RC (FORMERLY 2A MODIFIED)	NB	\$27.00 (* 26)	NA	NB			
SIZE NOS 57, 3 & 1 (FORMERLY 2B, 3A & 4)	NB	\$32.00 (* 33)	NA	NB			
SIZE NO. 67 (FORMERLY 2)	NB	\$32.00 (* 39)	NA	NB			
SIZE NO. 8 (FORMERLY 1B)	NB	\$38.00 (* 42)	NA	NB			
SIZE NO. 8-1% (FORMERLY 1B SEALING)	NB	\$38.00 (* 44)	NA	NB			
SIZE NO. R-3 (RIP-RAP)	NB	\$32.00 (* 46)	NA	NB			
SIZE NO. R-4 (RIP-RAP)	NB	\$32.00 (* 47)	NA	NB			
SIZE NO. R-5 (RIP-RAP)	NB	\$40.75 (* 50)	NA	NB			
SIZE NO. R-6 (RIP-RAP)	NB	\$41.38 (* 51)	NA	NB			
MINIMUM TONS FOR DELIVERY	NB	22 (* 54)	23	23			
Char-West COG	A & S Landscaping, Inc.	Amerkohl Aggregates, Inc.	Heidelberg Materials Northeast, LLC	Lindy Paving, Inc.			
GABION (4" - 8")	NB	\$32.50 (* 1)	\$37.75	NB			
SIZE NO. 10 (FORMERLY NO 1A)	\$30	\$27.50 (* 13)	\$30.25	NB			
SIZE NO. 2A	\$30	\$27.50 (* 19)	\$30.40	\$28.10			
SIZE NO. 2RC (FORMERLY 2A MODIFIED)	NB	\$27.50 (* 26)	\$30.40	\$28.10			
SIZE NOS 57, 3 & 1 (FORMERLY 2B, 3A & 4)	\$30	\$32.50 (* 33)	\$37.25	\$32.40			
SIZE NO. 67 (FORMERLY 2)	NB	\$32.50 (* 39)	\$38.25	\$32.40			
SIZE NO. 8 (FORMERLY 1B)	\$45	\$38.50 (* 42)	\$56.25	NB			
SIZE NO. 8-1% (FORMERLY 1B SEALING)	NB	\$38.50 (* 44)	\$63.25	NB			
SIZE NO. R-3 (RIP-RAP)	\$40	\$32.50 (* 46)	\$37.75	NB			
SIZE NO. R-4 (RIP-RAP)	\$45	\$32.50 (* 47)	\$40.25	NB			
SIZE NO. R-5 (RIP-RAP)	\$47	\$41.63 (* 50)	\$42.25	NB			
SIZE NO. R-6 (RIP-RAP)	NB	\$42.29 (* 51)	\$44	NB			
MINIMUM TONS FOR DELIVERY	TRI AXLE	22 (* 54)	23	23			



SHACOG PURCHASING ALLIANCE 2024

BID TABULATION - ROAD AGGREGATES - - LIMESTONE - DELIVERED AND DUMPED - PRICE PER TON

North Hills COG	A & S Landscaping, Inc.	Amerikohl Aggregates, Inc.	Heidelberg Materials Northeast, LLC	Lindy Paving, Inc.			
GABION (4" - 8")	NB	\$30 50 (* 1)	\$39 00	NB			
SIZE NO. 10 (FORMERLY NO 1A)	NB	\$25 50 (* 13)	\$31 50	NB			
SIZE NO. 2A	NB	\$25 50 (* 19)	\$31 65	\$30 10			
SIZE NO. 2RC (FORMERLY 2A MODIFIED)	NB	\$25 50 (* 26)	\$31 65	\$30 10			
SIZE NOS. 57, 3 & 1 (FORMERLY 2B, 3A & 4)	NB	\$30 50 (* 33)	\$38 50	\$34 40			
SIZE NO. 87 (FORMERLY 2)	NB	\$30 50 (* 39)	\$39 50	\$34 40			
SIZE NO. 8 (FORMERLY 1B)	NB	\$36 50 (* 42)	\$58	NB			
SIZE NO. 8-1% (FORMERLY 1B SEALING)	NB	\$36 50 (* 44)	\$65 00	NB			
SIZE NO. R-3 (RIP-RAP)	NB	\$30 50 (* 46)	\$39 00	NB			
SIZE NO. R-4 (RIP-RAP)	NB	\$30 50 (* 47)	\$41 00	NB			
SIZE NO. R-5 (RIP-RAP)	NB	\$39 00 (* 50)	\$43 50	NB			
SIZE NO. R-6 (RIP-RAP)	NB	\$39 56 (* 51)	\$45 25	NB			
MINIMUM TONS FOR DELIVERY	NB	22 (* 54)	23	23			
Quaker Valley COG	A & S Landscaping, Inc.	Amerikohl Aggregates, Inc.	Heidelberg Materials Northeast, LLC	Lindy Paving, Inc.			
GABION (4" - 8")	NB	\$30 50 (* 1)	\$39 00	NB			
SIZE NO. 10 (FORMERLY NO 1A)	NB	\$25 50 (* 13)	\$31 50	NB			
SIZE NO. 2A	NB	\$25 50 (* 19)	\$31 65	\$28 10			
SIZE NO. 2RC (FORMERLY 2A MODIFIED)	NB	\$25 50 (* 26)	\$31 65	\$28 10			
SIZE NOS. 57, 3 & 1 (FORMERLY 2B, 3A & 4)	NB	\$30 50 (* 33)	\$38 50	\$32 40			
SIZE NO. 67 (FORMERLY 2)	NB	\$30 50 (* 39)	\$39 50	\$32 40			
SIZE NO. 8 (FORMERLY 1B)	NB	\$36 50 (* 42)	\$58	NB			
SIZE NO. 8-1% (FORMERLY 1B SEALING)	NB	\$36 50 (* 44)	\$65 00	NB			
SIZE NO. R-3 (RIP-RAP)	NB	\$30 50 (* 46)	\$39 00	NB			
SIZE NO. R-4 (RIP-RAP)	NB	\$30 50 (* 47)	\$41 00	NB			
SIZE NO. R-5 (RIP-RAP)	NB	\$39 00 (* 50)	\$43 50	NB			
SIZE NO. R-6 (RIP-RAP)	NB	\$39 56 (* 51)	\$45 25	NB			
MINIMUM TONS FOR DELIVERY	NB	22 (* 54)	23	23			



SHACOG PURCHASING ALLIANCE

2024 BID TABULATION - ROAD AGGREGATES - - LIMESTONE - DELIVERED AND DUMPED - PRICE PER TON

South Hills Area COG	A & S Landscaping, Inc.	Amerkohl Aggregates, Inc.	Heidelberg Materials Northeast, LLC	Lindy Paving, Inc.			
GABION (4" - 8")	NB	\$31.00 (* 1)	\$37.75	NB			
SIZE NO 10 (FORMERLY NO 1A)	\$30	\$26.00 (* 13)	\$30.25	NB			
SIZE NO 2A	\$30	\$26.00 (* 19)	\$30.40	\$30.60			
SIZE NO 2RC (FORMERLY 2A MODIFIED)	NB	\$26.00 (* 26)	\$30.40	\$30.60			
SIZE NOS 57, 3 & 1 (FORMERLY 2B, 3A & 4)	\$30	\$31.00 (* 33)	\$37.25	\$34.90			
SIZE NO 67 (FORMERLY 2)	NB	\$31.00 (* 39)	\$38.25	\$34.90			
SIZE NO 8 (FORMERLY 1B)	\$45	\$37.00 (* 42)	\$56.25	NB			
SIZE NO 8-1% (FORMERLY 1B SEALING)	NB	\$37.00 (* 44)	\$63.25	NB			
SIZE NO R-3 (RIP-RAP)	\$40	\$31.00 (* 46)	\$37.75	NB			
SIZE NO R-4 (RIP-RAP)	\$45	\$31.00 (* 47)	\$40.25	NB			
SIZE NO R-5 (RIP-RAP)	\$47	\$39.88 (* 50)	\$42.25	NB			
SIZE NO R-6 (RIP-RAP)	NB	\$40.47 (* 51)	\$44	NB			
MINIMUM TONS FOR DELIVERY	TRIAxLE	22 (* 54)	23	23			
Steel Rivers COG	A & S Landscaping, Inc.	Amerkohl Aggregates, Inc.	Heidelberg Materials Northeast, LLC	Lindy Paving, Inc.			
GABION (4" - 8")	NB	\$32.50 (* 1)	\$33.40	NB			
SIZE NO 10 (FORMERLY NO 1A)	NB	\$27.50 (* 13)	\$25.90	NB			
SIZE NO 2A	NB	\$27.50 (* 19)	\$26.05	NB			
SIZE NO 2RC (FORMERLY 2A MODIFIED)	NB	\$27.50 (* 26)	\$26.05	NB			
SIZE NOS 57, 3 & 1 (FORMERLY 2B, 3A & 4)	NB	\$32.50 (* 33)	\$32.90	NB			
SIZE NO 67 (FORMERLY 2)	NB	\$32.50 (* 39)	\$33.90	NB			
SIZE NO 8 (FORMERLY 1B)	NB	\$38.50 (* 42)	\$52.40	NB			
SIZE NO 8-1% (FORMERLY 1B SEALING)	NB	\$38.50 (* 44)	\$59.40	NB			
SIZE NO R-3 (RIP-RAP)	NB	\$32.50 (* 46)	\$33.40	NB			
SIZE NO R-4 (RIP-RAP)	NB	\$32.50 (* 47)	\$35.90	NB			
SIZE NO R-5 (RIP-RAP)	NB	\$41.83 (* 50)	\$37.90	NB			
SIZE NO R-6 (RIP-RAP)	NB	\$42.29 (* 51)	\$39.65	NB			
MINIMUM TONS FOR DELIVERY	NB	22 (* 54)	23	NB			



SHACOG PURCHASING ALLIANCE

2024 BID TABULATION - ROAD AGGREGATES - - LIMESTONE - DELIVERED AND DUMPED - PRICE PER TON

Turtle Creek Valley COG	A & S Landscaping, Inc.	Amerikohl Aggregates, Inc.	Heidelberg Materials Northeast, LLC	Lindy Paving, Inc.			
GABION (4" - 8")	NB	\$28 05 (* 1)	\$33 40	NB			
SIZE NO. 10 (FORMERLY NO. 1A)	NB	\$24 05 (* 13)	\$25 90	NB			
SIZE NO. 2A	NB	\$24 05 (* 19)	\$26 05	NB			
SIZE NO. 2RC (FORMERLY 2A MODIFIED)	NB	\$24 05 (* 26)	\$26 05	NB			
SIZE NOS. 57, 3 & 1 (FORMERLY 2B, 3A & 4)	NB	\$28 05 (* 33)	\$32 90	NB			
SIZE NO. 67 (FORMERLY 2)	NB	\$28 05 (* 39)	\$33 90	NB			
SIZE NO. 8 (FORMERLY 1B)	NB	\$45 05 (* 42)	\$52 40	NB			
SIZE NO. 8-1% (FORMERLY 1B SEALING)	NB	\$45 05 (* 44)	\$59 40	NB			
SIZE NO. R-3 (RIP-RAP)	NB	\$28 05 (* 46)	\$33 40	NB			
SIZE NO. R-4 (RIP-RAP)	NB	\$28 05 (* 47)	\$35 90	NB			
SIZE NO. R-5 (RIP-RAP)	NB	\$33 81 (* 50)	\$37 90	NB			
SIZE NO. R-6 (RIP-RAP)	NB	\$35 57 (* 51)	\$39 65	NB			
MINIMUM TONS FOR DELIVERY	NB	22 (* 54)	23	NB			



SHACOG PURCHASING ALLIANCE

2024 BID TABULATION - ROAD AGGREGATES

LIMESTONE -- DELIVERED AND DUMPED - PRICE PER TON VENDOR NOTES

- * 1 - NA
- * 6 - NA
- * 9 - NA
- * 13 - NA
- * 19 - NA
- * 22 - NA
- * 26 - NA
- * 27 - NA
- * 33 - NA
- * 34 - NA
- * 39 - NA
- * 40 - NA
- * 41 - NA
- * 42 - NA
- * 43 - NA
- * 44 - NA
- * 45 - NA
- * 46 - NA
- * 47 - NA
- * 48 - NA
- * 49 - NA
- * 50 - NA
- * 51 - NA
- * 52 - NA
- * 53 - NA
- * 54 - 22



SHACOG PURCHASING ALLIANCE

2024 BID TABULATION - ROAD AGGREGATES

LIMESTONE - - FOB PICKED UP BY MUNICIPALITY - PRICE PER TON

Allegheny Valley North COG	A & S Landscaping, Inc.	Amerkohl Aggregates, Inc.	Heidelberg Materials Northeast, LLC	Lindy Paving, Inc.			
SIZE NO. 2A	\$30	NA (* 22)	NA	NB			
SIZE NOS 57, 3 & 1 (FORMERLY 2B, 3A & 4)	\$30	NA (* 34)	NA	NB			
SIZE NO 8 (FORMERLY 1B)	\$45	NA (* 41)	NA	NB			
SIZE NO R-4 (RIP-RAP)	\$45	NA (* 48)	NA	NB			
MINIMUM TONS FOR PICKUP	NONE	NA (* 53)	0	NB			
Butler County COG	A & S Landscaping, Inc.	Amerkohl Aggregates, Inc.	Heidelberg Materials Northeast, LLC	Lindy Paving, Inc.			
SIZE NO. 2A	\$30	NA (* 22)	NA	NB			
SIZE NOS 57, 3 & 1 (FORMERLY 2B, 3A & 4)	\$30	NA (* 34)	NA	NB			
SIZE NO 8 (FORMERLY 1B)	\$45	NA (* 41)	NA	NB			
SIZE NO R-4 (RIP-RAP)	\$45	NA (* 48)	NA	NB			
MINIMUM TONS FOR PICKUP	NONE	NA (* 53)	0	NB			
Char-West COG	A & S Landscaping, Inc.	Amerkohl Aggregates, Inc.	Heidelberg Materials Northeast, LLC	Lindy Paving, Inc.			
SIZE NO. 2A	\$30	NA (* 22)	NA	NB			
SIZE NOS 57, 3 & 1 (FORMERLY 2B, 3A & 4)	\$30	NA (* 34)	NA	NB			
SIZE NO 8 (FORMERLY 1B)	\$45	NA (* 41)	NA	NB			
SIZE NO R-4 (RIP-RAP)	\$45	NA (* 48)	NA	NB			
MINIMUM TONS FOR PICKUP	NONE	NA (* 53)	0	NB			
North Hills COG	A & S Landscaping, Inc.	Amerkohl Aggregates, Inc.	Heidelberg Materials Northeast, LLC	Lindy Paving, Inc.			
SIZE NO. 2A	\$30	NA (* 22)	NA	NB			
SIZE NOS 57, 3 & 1 (FORMERLY 2B, 3A & 4)	\$30	NA (* 34)	NA	NB			
SIZE NO 8 (FORMERLY 1B)	\$45	NA (* 41)	NA	NB			
SIZE NO R-4 (RIP-RAP)	\$45	NA (* 48)	NA	NB			
MINIMUM TONS FOR PICKUP	NONE	NA (* 53)	0	NB			



SHACOG PURCHASING ALLIANCE

2024 BID TABULATION - ROAD AGGREGATES - - LIMESTONE - FOB PICKED UP BY MUNICIPALITY - PRICE PER TON

Quaker Valley COG	A & S Landscaping, Inc.	Amerikohl Aggregates, Inc.	Heidelberg Materials Northeast, LLC	Lindy Paving, Inc.			
SIZE NO 2A	\$30	NA (* 22)	NA	NB			
SIZE NOS 57, 3 & 1 (FORMERLY 2B, 3A & 4)	\$30	NA (* 34)	NA	NB			
SIZE NO 8 (FORMERLY 1B)	\$45	NA (* 41)	NA	NB			
SIZE NO R-4 (RIP-RAP)	\$45	NA (* 48)	NA	NB			
MINIMUM TONS FOR PICKUP	NONE	NA (* 53)	0	NB			
South Hills Area COG	A & S Landscaping, Inc.	Amerikohl Aggregates, Inc.	Heidelberg Materials Northeast, LLC	Lindy Paving, Inc.			
SIZE NO 2A	\$30	NA (* 22)	NA	NB			
SIZE NOS 57, 3 & 1 (FORMERLY 2B, 3A & 4)	\$30	NA (* 34)	NA	NB			
SIZE NO 8 (FORMERLY 1B)	\$45	NA (* 41)	NA	NB			
SIZE NO R-4 (RIP-RAP)	\$45	NA (* 48)	NA	NB			
MINIMUM TONS FOR PICKUP	NONE	NA (* 53)	0	NB			
Steel Rivers COG	A & S Landscaping, Inc.	Amerikohl Aggregates, Inc.	Heidelberg Materials Northeast, LLC	Lindy Paving, Inc.			
SIZE NO 2A	\$30	NA (* 22)	NA	NB			
SIZE NOS 57, 3 & 1 (FORMERLY 2B, 3A & 4)	\$30	NA (* 34)	NA	NB			
SIZE NO 8 (FORMERLY 1B)	\$45	NA (* 41)	NA	NB			
SIZE NO R-4 (RIP-RAP)	\$45	NA (* 48)	NA	NB			
MINIMUM TONS FOR PICKUP	NONE	NA (* 53)	0	NB			
Turtle Creek Valley COG	A & S Landscaping, Inc.	Amerikohl Aggregates, Inc.	Heidelberg Materials Northeast, LLC	Lindy Paving, Inc.			
SIZE NO 2A	\$30	NA (* 22)	NA	NB			
SIZE NOS 57, 3 & 1 (FORMERLY 2B, 3A & 4)	\$30	NA (* 34)	NA	NB			
SIZE NO 8 (FORMERLY 1B)	\$45	NA (* 41)	NA	NB			
SIZE NO R-4 (RIP-RAP)	\$45	NA (* 48)	NA	NB			
MINIMUM TONS FOR PICKUP	NONE	NA (* 53)	0	NB			



SHACOG PURCHASING ALLIANCE
2024 BID TABULATION - ROAD AGGREGATES
LIMESTONE - FOB PICKED UP BY MUNICIPALITY - PRICE PER TON

- * 1 - NA
- * 6 - NA
- * 9 - NA
- * 13 - NA
- * 19 - NA
- * 22 - NA
- * 26 - NA
- * 27 - NA
- * 33 - NA
- * 34 - NA
- * 39 - NA
- * 40 - NA
- * 41 - NA
- * 42 - NA
- * 43 - NA
- * 44 - NA
- * 45 - NA
- * 46 - NA
- * 47 - NA
- * 48 - NA
- * 49 - NA
- * 50 - NA
- * 51 - NA
- * 52 - NA
- * 53 - NA
- * 54 - 22



SHACOG PURCHASING ALLIANCE

2024 BID TABULATION - ROAD AGGREGATES

SAND - - DELIVERED AND DUMPED - PRICE PER TON

Allegheny Valley North COG	A & S Landscaping, Inc.	Amerikohl Aggregates, Inc.	Heidelberg Materials Northeast, LLC	Lindy Paving, Inc.			
MINIMUM TONS FOR DELIVERY	NB	NA (* 31)	0	NB			
Butler County COG	A & S Landscaping, Inc.	Amerikohl Aggregates, Inc.	Heidelberg Materials Northeast, LLC	Lindy Paving, Inc.			
MINIMUM TONS FOR DELIVERY	NB	NA (* 31)	0	23			
Char-West COG	A & S Landscaping, Inc.	Amerikohl Aggregates, Inc.	Heidelberg Materials Northeast, LLC	Lindy Paving, Inc.			
PIPE BEDDING	\$35	NA (* 4)	NA	\$31 00			
RIVER SAND	NB	NA (* 14)	NA	\$31 00			
STONE SAND	\$35	NA (* 20)	NA	NB			
MINIMUM TONS FOR DELIVERY	TRIAXLE	NA (* 31)	0	23			
North Hills COG	A & S Landscaping, Inc.	Amerikohl Aggregates, Inc.	Heidelberg Materials Northeast, LLC	Lindy Paving, Inc.			
PIPE BEDDING	NB	NA (* 4)	NA	\$32 00			
RIVER SAND	NB	NA (* 14)	NA	\$32 00			
MINIMUM TONS FOR DELIVERY	NB	NA (* 31)	0	23			
Quaker Valley COG	A & S Landscaping, Inc.	Amerikohl Aggregates, Inc.	Heidelberg Materials Northeast, LLC	Lindy Paving, Inc.			
PIPE BEDDING	NB	NA (* 4)	NA	\$31 00			
RIVER SAND	NB	NA (* 14)	NA	\$31 00			
MINIMUM TONS FOR DELIVERY	NB	NA (* 31)	0	23			
South Hills Area COG	A & S Landscaping, Inc.	Amerikohl Aggregates, Inc.	Heidelberg Materials Northeast, LLC	Lindy Paving, Inc.			
PIPE BEDDING	\$35	NA (* 4)	NA	\$32 00			
RIVER SAND	NB	NA (* 14)	NA	\$32 00			
STONE SAND	\$35	NA (* 20)	NA	NB			
MINIMUM TONS FOR DELIVERY	TRIAXLE	NA (* 31)	0	23			



SHACOG PURCHASING ALLIANCE

2024 BID TABULATION - ROAD AGGREGATES - - SAND - DELIVERED AND DUMPED - PRICE PER TON

Steel Rivers COG	A & S Landscaping, Inc.	Amerikohl Aggregates, Inc.	Heidelberg Materials Northeast, LLC	Lindy Paving, Inc.			
PIPE BEDDING	NB	NA (* 4)	NA	\$34.00			
RIVER SAND	NB	NA (* 14)	NA	\$34.00			
MINIMUM TONS FOR DELIVERY	NB	NA (* 31)	0	NB			
Turtle Creek Valley COG	A & S Landscaping, Inc.	Amerikohl Aggregates, Inc.	Heidelberg Materials Northeast, LLC	Lindy Paving, Inc.			
MINIMUM TONS FOR DELIVERY	NB	NA (* 31)	0	NB			

SAND - - DELIVERED AND DUMPED - PRICE PER TON VENDOR NOTES	
* 4 - NA	
* 5 - NA	
* 11 - NA	
* 14 - NA	
* 20 - NA	
* 23 - NA	
* 31 - NA	
* 32 - NA	



SHACOG PURCHASING ALLIANCE

2024 BID TABULATION - ROAD AGGREGATES

SAND - - FOB PICKED UP BY MUNICIPALITY - PRICE PER TON

Allegheny Valley North COG	A & S Landscaping, Inc.	Amerkohl Aggregates, Inc.	Heidelberg Materials Northeast, LLC	Lindy Paving, Inc.			
PIPE BEDDING	\$35	NA (* 5)	NA	NB			
RIVER SAND	\$35	NA (* 11)	NA	NB			
STONE SAND	\$35	NA (* 23)	NA	NB			
MINIMUM TONS FOR PICKUP	NONE	NA (* 32)	0	NB			
Butler County COG	A & S Landscaping, Inc.	Amerkohl Aggregates, Inc.	Heidelberg Materials Northeast, LLC	Lindy Paving, Inc.			
PIPE BEDDING	\$35	NA (* 5)	NA	NB			
RIVER SAND	\$35	NA (* 11)	NA	NB			
STONE SAND	\$35	NA (* 23)	NA	NB			
MINIMUM TONS FOR PICKUP	NONE	NA (* 32)	0	NB			
Char-West COG	A & S Landscaping, Inc.	Amerkohl Aggregates, Inc.	Heidelberg Materials Northeast, LLC	Lindy Paving, Inc.			
PIPE BEDDING	\$35	NA (* 5)	NA	NB			
RIVER SAND	\$35	NA (* 11)	NA	NB			
STONE SAND	\$35	NA (* 23)	NA	NB			
MINIMUM TONS FOR PICKUP	NONE	NA (* 32)	0	NB			
North Hills COG	A & S Landscaping, Inc.	Amerkohl Aggregates, Inc.	Heidelberg Materials Northeast, LLC	Lindy Paving, Inc.			
PIPE BEDDING	\$35	NA (* 5)	NA	NB			
RIVER SAND	\$35	NA (* 11)	NA	NB			
STONE SAND	\$35	NA (* 23)	NA	NB			
MINIMUM TONS FOR PICKUP	NONE	NA (* 32)	0	NB			
Quaker Valley COG	A & S Landscaping, Inc.	Amerkohl Aggregates, Inc.	Heidelberg Materials Northeast, LLC	Lindy Paving, Inc.			
PIPE BEDDING	\$35	NA (* 5)	NA	NB			
RIVER SAND	\$35	NA (* 11)	NA	NB			
STONE SAND	\$35	NA (* 23)	NA	NB			
MINIMUM TONS FOR PICKUP	NONE	NA (* 32)	0	NB			



SHACOG PURCHASING ALLIANCE

2024 BID TABULATION - ROAD AGGREGATES - - SAND - FOB PICKED UP BY MUNICIPALITY - PRICE PER TON

South Hills Area COG	A & S Landscaping, Inc.	Amerkohl Aggregates, Inc.	Heidelberg Materials Northeast, LLC	Lindy Paving, Inc.			
PIPE BEDDING	\$35	NA (* 5)	NA	NB			
RIVER SAND	\$35	NA (* 11)	NA	NB			
STONE SAND	\$35	NA (* 23)	NA	NB			
MINIMUM TONS FOR PICKUP	NONE	NA (* 32)	0	NB			
Steel Rivers COG	A & S Landscaping, Inc.	Amerkohl Aggregates, Inc.	Heidelberg Materials Northeast, LLC	Lindy Paving, Inc.			
PIPE BEDDING	\$35	NA (* 5)	NA	NB			
RIVER SAND	\$35	NA (* 11)	NA	NB			
STONE SAND	\$35	NA (* 23)	NA	NB			
MINIMUM TONS FOR PICKUP	NONE	NA (* 32)	0	NB			
Turtle Creek Valley COG	A & S Landscaping, Inc.	Amerkohl Aggregates, Inc.	Heidelberg Materials Northeast, LLC	Lindy Paving, Inc.			
PIPE BEDDING	\$35	NA (* 5)	NA	NB			
RIVER SAND	\$35	NA (* 11)	NA	NB			
STONE SAND	\$35	NA (* 23)	NA	NB			
MINIMUM TONS FOR PICKUP	NONE	NA (* 32)	0	NB			

SAND - - FOB PICKED UP BY MUNICIPALITY - PRICE PER TON VENDOR NOTES

- * 4 - NA
- * 5 - NA
- * 11 - NA
- * 14 - NA
- * 20 - NA
- * 23 - NA
- * 31 - NA
- * 32 - NA



SHACOG PURCHASING ALLIANCE

2024 BID TABULATION - ROAD AGGREGATES

SLAG (AIR COOLED) - - DELIVERED AND DUMPED - PRICE PER TON

Allegheny Valley North COG	A & S Landscaping, Inc.	Amerkohl Aggregates, Inc.	Heidelberg Materials Northeast, LLC	Lindy Paving, Inc.			
MINIMUM TONS FOR DELIVERY	NB	NA (* 35)	0	NB			
Butler County COG	A & S Landscaping, Inc.	Amerkohl Aggregates, Inc.	Heidelberg Materials Northeast, LLC	Lindy Paving, Inc.			
MINIMUM TONS FOR DELIVERY	NB	NA (* 35)	0	NB			
Char-West COG	A & S Landscaping, Inc.	Amerkohl Aggregates, Inc.	Heidelberg Materials Northeast, LLC	Lindy Paving, Inc.			
SIZE NOS 57, 3 & 1 (FORMERLY 2B, 3A & 4)	\$30	NA (* 30)	NA	NB			
MINIMUM TONS FOR DELIVERY	TRI AXLE	NA (* 35)	0	NB			
North Hills COG	A & S Landscaping, Inc.	Amerkohl Aggregates, Inc.	Heidelberg Materials Northeast, LLC	Lindy Paving, Inc.			
MINIMUM TONS FOR DELIVERY	NB	NA (* 35)	0	NB			
Quaker Valley COG	A & S Landscaping, Inc.	Amerkohl Aggregates, Inc.	Heidelberg Materials Northeast, LLC	Lindy Paving, Inc.			
MINIMUM TONS FOR DELIVERY	NB	NA (* 35)	0	NB			
South Hills Area COG	A & S Landscaping, Inc.	Amerkohl Aggregates, Inc.	Heidelberg Materials Northeast, LLC	Lindy Paving, Inc.			
SIZE NOS 57, 3 & 1 (FORMERLY 2B, 3A & 4)	\$30	NA (* 30)	NA	NB			
MINIMUM TONS FOR DELIVERY	TRI AXLE	NA (* 35)	0	NB			
Steel Rivers COG	A & S Landscaping, Inc.	Amerkohl Aggregates, Inc.	Heidelberg Materials Northeast, LLC	Lindy Paving, Inc.			
MINIMUM TONS FOR DELIVERY	NB	NA (* 35)	0	NB			
Turtle Creek Valley COG	A & S Landscaping, Inc.	Amerkohl Aggregates, Inc.	Heidelberg Materials Northeast, LLC	Lindy Paving, Inc.			
MINIMUM TONS FOR DELIVERY	NB	NA (* 35)	0	NB			



SHACOG PURCHASING ALLIANCE

2024 BID TABULATION - ROAD AGGREGATES

SLAG (AIR COOLED) - - DELIVERED AND DUMPED - PRICE PER TON VENDOR NOTES
* 2 - NA
* 8 - NA
* 10 - NA
* 16 - NA
* 17 - NA
* 24 - NA
* 28 - NA
* 30 - NA
* 35 - NA
* 38 - NA



SHACOG PURCHASING ALLIANCE

2024 BID TABULATION - ROAD AGGREGATES

SLAG (AIR COOLED) - - FOB PICKED UP BY MUNICIPALITY - PRICE PER TON

Allegheny Valley North COG	A & S Landscaping, Inc.	Amerkohl Aggregates, Inc.	Heidelberg Materials Northeast, LLC	Lindy Paving, Inc.			
MINIMUM TONS FOR PICKUP	NB	NA (* 38)	0	NB			
Butler County COG	A & S Landscaping, Inc.	Amerkohl Aggregates, Inc.	Heidelberg Materials Northeast, LLC	Lindy Paving, Inc.			
MINIMUM TONS FOR PICKUP	NB	NA (* 38)	0	NB			
Char-West COG	A & S Landscaping, Inc.	Amerkohl Aggregates, Inc.	Heidelberg Materials Northeast, LLC	Lindy Paving, Inc.			
MINIMUM TONS FOR PICKUP	NB	NA (* 38)	0	NB			
North Hills COG	A & S Landscaping, Inc.	Amerkohl Aggregates, Inc.	Heidelberg Materials Northeast, LLC	Lindy Paving, Inc.			
MINIMUM TONS FOR PICKUP	NB	NA (* 38)	0	NB			
Quaker Valley COG	A & S Landscaping, Inc.	Amerkohl Aggregates, Inc.	Heidelberg Materials Northeast, LLC	Lindy Paving, Inc.			
MINIMUM TONS FOR PICKUP	NB	NA (* 38)	0	NB			
South Hills Area COG	A & S Landscaping, Inc.	Amerkohl Aggregates, Inc.	Heidelberg Materials Northeast, LLC	Lindy Paving, Inc.			
MINIMUM TONS FOR PICKUP	NB	NA (* 38)	0	NB			
Steel Rivers COG	A & S Landscaping, Inc.	Amerkohl Aggregates, Inc.	Heidelberg Materials Northeast, LLC	Lindy Paving, Inc.			
MINIMUM TONS FOR PICKUP	NB	NA (* 38)	0	NB			
Turtle Creek Valley COG	A & S Landscaping, Inc.	Amerkohl Aggregates, Inc.	Heidelberg Materials Northeast, LLC	Lindy Paving, Inc.			
MINIMUM TONS FOR PICKUP	NB	NA (* 38)	0	NB			



SHACOG PURCHASING ALLIANCE

2024 BID TABULATION - ROAD AGGREGATES

SLAG (AIR COOLED) - - FOB PICKED UP BY MUNICIPALITY - PRICE PER TON VENDOR NOTES
* 2 - NA
* 8 - NA
* 10 - NA
* 16 - NA
* 17 - NA
* 24 - NA
* 28 - NA
* 30 - NA
* 35 - NA
* 38 - NA

ROAD AGGREGATES NAME AND ADDRESS OF BIDDER'S SOURCE OF SUPPLY
A & S Landscaping, Inc -
Amerikohl Aggregates, Inc. -
Heidelberg Materials Northeast, LLC -
Lindy Paving, Inc -

TOWNSHIP OF O'HARA
ALLEGHENY COUNTY, PENNSYLVANIA

**A RESOLUTION OF THE TOWNSHIP OF O'HARA AUTHORIZING THE
AWARD OF SPRING COMMODITIES BIDS RECEIVED BY THE SOUTH
HILLS AREA COUNCIL OF GOVERNMENTS**

WHEREAS, the South Hills Area Council of Governments opened bids received for Spring Commodities on March 7, 2024, which include road surface materials, road paint, guide rails, manhole inserts, plastic and corrugated metal pipes, top soil, fertilizers, wood carpet, portable toilet rental service and other items; and

WHEREAS, upon review of the bids, it has been determined that the bids received by the South Hills Area Council of Governments are the lowest and most responsible bidders.

NOW, THEREFORE BE IT RESOLVED that the bids received by the South Hills Area Council of Governments for Spring Commodities are awarded based on the attached list of bid unit prices.

RESOLVED BY Council vote of ___ to ___ on _____, 2024.

ATTEST:

TOWNSHIP OF O'HARA

Julie A. Jakubec, CPA, CGMA
Township Manager

Cassandra R. Eccles
President of Council

Adopted _____

001-General Fund

ACCT NO#	ACCOUNT NAME	BEGINNING BALANCE	M-T-D ACTIVITY	Y-T-D ACTIVITY	CURRENT BALANCE
ASSETS					
001.100.001.000	Dollar Bank	729,770.79	348,664.95	462,756.71	1,192,527.50
001.100.001.001	DO NOT USE	0.00	0.00	0.00	0.00
001.100.001.002	PNC Pennvest	0.00	0.00	0.00	0.00
001.100.001.003	EIT Checking	0.00	0.00	0.00	0.00
001.100.001.004	Real Estate Tax Cash	0.00	0.00	0.00	0.00
001.100.001.006	Defined Contribution	48,059.53	0.12	48,030.70CR	28.83
001.100.001.007	PNC Community Center	0.00	0.00	0.00	0.00
001.100.002.001	PNC History Book	0.00	0.00	0.00	0.00
001.100.003.001	Emergency Equipment	428,029.65	2,180.16	3,700.00	431,729.65
001.100.004.001	PNC Parkland	0.00	0.00	0.00	0.00
001.100.004.002	Cash-Payroll	28,956.43	2,800.65	9,627.07CR	19,329.36
001.100.005.001	Municipal Building	32,079.26	78.35	16,560.05CR	15,519.21
001.100.009.001	American Rescue Plan	0.00	0.00	0.00	0.00
001.100.015.001	Citizens-Bond	0.00	0.00	0.00	0.00
001.100.017.001	PNC Brownshill	0.00	0.00	0.00	0.00
001.120.001.001	PLGIT	0.00	0.00	0.00	0.00
001.120.001.002	PLGIT Plus	0.00	0.00	0.00	0.00
001.120.001.003	PLGIT Term	0.00	0.00	0.00	0.00
001.120.001.004	Federated Investors	0.00	0.00	0.00	0.00
001.120.001.005	Cash Holding Account	0.00	0.00	0.00	0.00
001.120.001.006	S&T Bank	0.00	0.00	0.00	0.00
001.120.002.002	PLGIT History Book	0.00	0.00	0.00	0.00
001.120.003.001	PLGIT Emergency Equipment	0.00	0.00	0.00	0.00
001.120.004.001	PLGIT Parkland	0.00	0.00	0.00	0.00
001.120.005.002	PLGIT Municipal Building	0.00	0.00	0.00	0.00
001.120.009.001	PLGIT Pub. Serv. Equip	0.00	0.00	0.00	0.00
001.120.009.005	S&T Bank Pub Sevr Equip	0.00	0.00	0.00	0.00
001.120.015.001	PLGIT Bond	0.00	0.00	0.00	0.00
001.120.015.005	S&T General Fund	0.00	0.00	0.00	0.00
001.120.017.005	S&T Bank Brownshill	0.00	0.00	0.00	0.00
001.120.019.001	PLGIT Sewer Reserve	0.00	0.00	0.00	0.00
001.120.019.005	S&T Bank Sewer Reserve	0.00	0.00	0.00	0.00
001.130.000.018	Due from community center fund	0.00	0.00	0.00	0.00
001.130.002.000	Due From History Book Fund	0.00	0.00	0.00	0.00
001.130.003.000	Due From Emergency Equipment	0.00	0.00	0.00	0.00
001.130.004.000	Due From ARP	0.00	0.00	0.00	0.00
001.130.005.000	Due From Municipal Building	0.00	0.00	0.00	0.00
001.130.006.000	Due From Refundable Fund	30,600.00	0.00	0.00	30,600.00
001.130.008.000	Due From Sewer Fund	3,615,343.35	162,261.98	100,641.25CR	3,514,702.10
001.130.009.000	Due From Storm Water Fund	273,493.71	219,395.68CR	443,201.87CR	169,708.16CR
001.130.015.000	Due From Bond Fund	0.00	0.00	0.00	0.00
001.130.016.000	Due From Sewer Bond Fund	0.00	0.00	0.00	0.00
001.130.018.000	Due From Community Center Fund	0.00	0.00	0.00	0.00
001.130.035.000	Due From Highway Aid Fund	13,000.80	0.00	3,463.63	16,464.43
001.131.001.000	Misc. Receivable	87,118.94	0.00	0.00	87,118.94
001.131.002.000	Outside Receivable	47,200.00	0.00	0.00	47,200.00
001.132.001.000	Due from Outside Organizations	0.00	0.00	0.00	0.00
001.132.002.000	Due From PEMA/FEMA	0.00	0.00	0.00	0.00
001.140.000.004	LST Receivable	129,068.27	0.00	0.00	129,068.27

UNAUDITED - 4/9/2024

001-General Fund

ACCT NO#	ACCOUNT NAME	BEGINNING BALANCE	M-T-D ACTIVITY	Y-T-D ACTIVITY	CURRENT BALANCE
001.140.001.000	Real Estate Rec Current	40,235.10	0.00	0.00	40,235.10
001.140.006.000	EIT Receivable	1,200,000.00	0.00	0.00	1,200,000.00
001.142.001.000	Delinquent RET Rec	280,106.11	0.00	0.00	280,106.11
001.144.001.000	Liened Tax Receivable	0.00	0.00	0.00	0.00
001.145.001.000	Liened Sewer Fee	0.00	0.00	0.00	0.00
001.145.002.000	Liened Water Fee	5,836.83	0.00	0.00	5,836.83
001.146.001.000	Doubtful Real Estate Tax	8,403.18CR	0.00	0.00	8,403.18CR
001.146.002.000	Doubtful utility Fee	116.74CR	0.00	0.00	116.74CR
001.147.001.000	Interest Receivable	0.00	0.00	0.00	0.00
TOTAL ASSETS		6,980,378.85	296,590.53	148,140.60CR	6,832,238.25

LIABILITIES

001.200.001.000	Vouchers Payable	1,027,523.18CR	313,042.80CR	199,008.78CR	1,226,531.96CR
001.201.001.000	Accrued Payroll Liability	72,504.85CR	0.00	0.00	72,504.85CR
001.210.001.000	Federal Income Tax withheld	0.00	0.00	0.00	0.00
001.211.192.001	FICA-Employee	4,174.90CR	0.00	0.00	4,174.90CR
001.211.192.002	FICA-Employer	4,174.90CR	0.00	0.00	4,174.90CR
001.212.001.000	EIT withheld	0.00	0.00	0.00	0.00
001.214.001.000	Employee Pension	3,091.09CR	0.00	0.00	3,091.09CR
001.217.001.000	State Income Tax withheld	0.00	0.00	0.00	0.00
001.218.001.000	Union Dues	0.00	0.00	0.00	0.00
001.219.001.000	LST withheld	5,014.39CR	0.00	0.00	5,014.39CR
001.221.001.000	SUI Deduction	10,401.88CR	0.00	0.00	10,401.88CR
001.222.001.000	AFLAC Insurance	19.20CR	0.00	0.00	19.20CR
001.223.001.000	Garnishments Withheld	783.00CR	0.00	0.00	783.00CR
001.224.001.000	Miscellaneous Deductions	7,257.64CR	0.00	0.00	7,257.64CR
001.224.001.001	Credit Union	36.95CR	0.00	0.00	36.95CR
001.230.002.000	Due to History Book Fund	0.00	0.00	0.00	0.00
001.230.003.000	Due to Emergency Equipment Res	0.00	0.00	0.00	0.00
001.230.004.000	Due to American Rescue Plan	0.00	0.00	0.00	0.00
001.230.005.000	Due to Municipal Building Rese	0.00	0.00	0.00	0.00
001.230.006.000	Due to refundables	307,307.02CR	0.00	10,000.00	297,307.02CR
001.230.008.000	Due to Sewer Fund	0.00	465.00CR	520.00CR	520.00CR
001.230.009.000	Due to Stormwater Fund	0.00	0.00	36,361.92CR	36,361.92CR
001.230.015.000	Due to Bond Fund	0.00	0.00	0.00	0.00
001.230.017.000	Due to Brownhill	0.00	0.00	0.00	0.00
001.230.035.000	Due to Highway Aid Fund	0.00	0.00	0.00	0.00
001.240.001.000	Held Checks	3,963.65CR	0.00	0.00	3,963.65CR
001.240.002.000	Donations for Future Projects	29,951.22CR	0.00	0.00	29,951.22CR
001.245.000.000	Cash Held	6,000.00CR	0.00	0.00	6,000.00CR
001.250.001.000	Fox Hall Road Deposit	0.00	0.00	0.00	0.00
001.250.001.001	910 Field Club Road	0.00	0.00	0.00	0.00
001.250.002.009	Fire Escrow/Twin Maple D	0.00	0.00	0.00	0.00
001.252.001.000	Deferred Revenue	1,505,719.64CR	0.00	0.00	1,505,719.64CR
001.252.001.001	Deferred Revenue ARP	0.00	0.00	0.00	0.00
001.252.002.000	EIT Deferred	0.00	0.00	0.00	0.00
TOTAL LIABILITIES		2,987,923.51CR	313,507.80CR	225,890.70CR	3,213,814.21CR

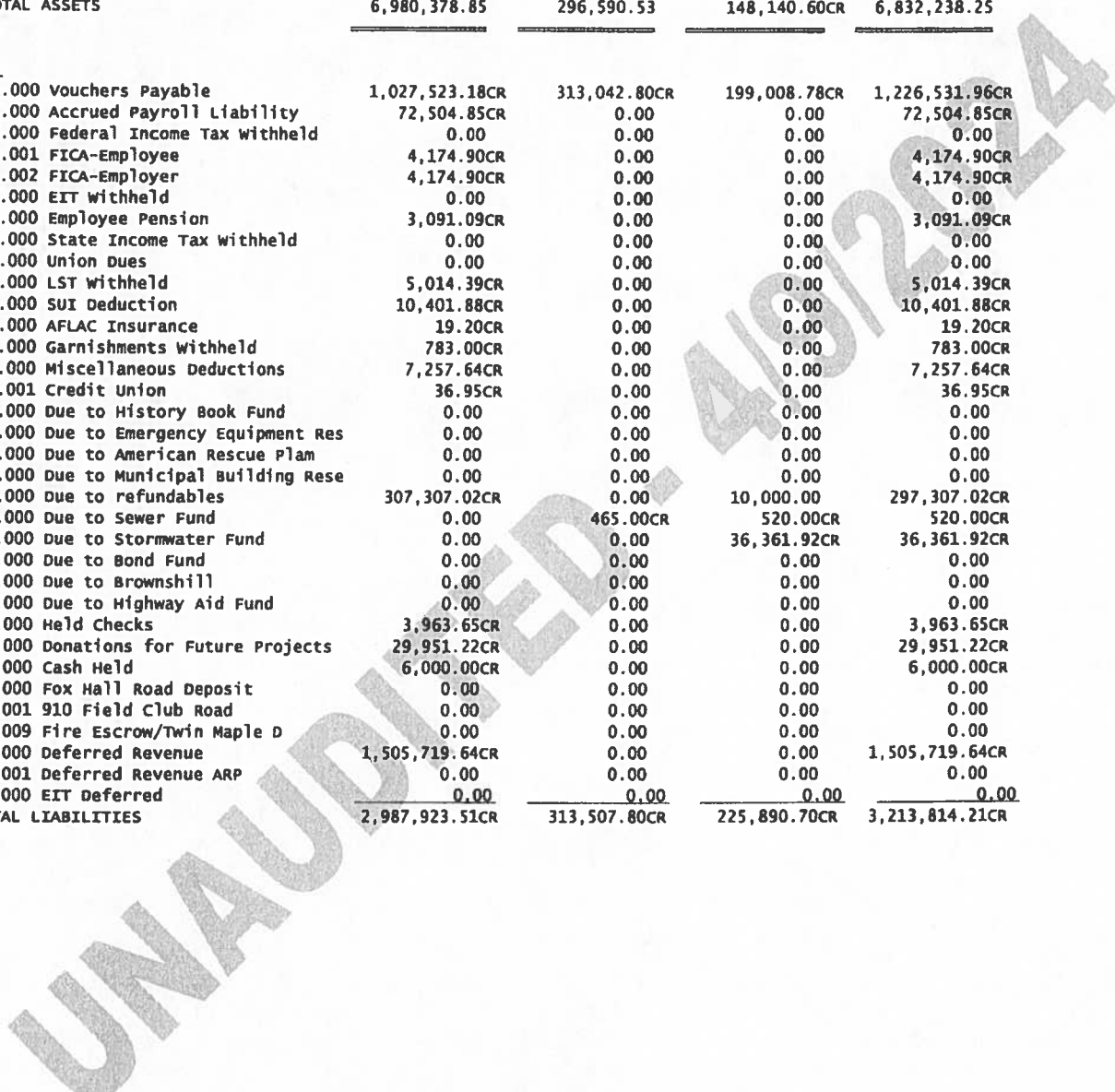

001-General Fund

ACCT NO#	ACCOUNT NAME	BEGINNING BALANCE	M-T-D ACTIVITY	Y-T-D ACTIVITY	CURRENT BALANCE
FUND EQUITY					
001.273.001.000	Reserve for Encumbrances	0.00	0.00	0.00	0.00
001.279.000.000	Unreserved Fund Balance	365,945.11	0.00	0.00	365,945.11
001.279.001.000	Nonspendable	0.00	0.00	0.00	0.00
001.279.002.000	Restricted	0.00	0.00	0.00	0.00
001.279.003.000	Committed	435,000.00CR	0.00	0.00	435,000.00CR
001.279.003.003	Committed Fire	0.00	0.00	0.00	0.00
001.279.003.005	Committed Municipal Building	0.00	0.00	0.00	0.00
001.279.003.017	Committed Brownshill	0.00	0.00	0.00	0.00
001.279.003.019	Committed Sewer Reserve	0.00	0.00	0.00	0.00
001.279.004.000	Assigned	0.00	0.00	0.00	0.00
001.279.004.002	Assigned History Book	0.00	0.00	0.00	0.00
001.279.004.003	Assigned Fire	0.00	0.00	0.00	0.00
001.279.004.004	Assigned Park	21,595.70CR	0.00	0.00	21,595.70CR
001.279.004.005	Assigned Municipal Building	0.00	0.00	0.00	0.00
001.279.004.009	Assigned Public Service Equip.	0.00	0.00	0.00	0.00
001.279.004.015	Assigned Bond	0.00	0.00	0.00	0.00
001.279.004.017	Assigned Brownshill	0.00	0.00	0.00	0.00
001.279.004.019	Assigned Sewer Reserve	0.00	0.00	0.00	0.00
001.279.005.000	Unassigned	3,901,804.75CR	0.00	0.00	3,901,804.75CR
TOTAL REVENUES		0.00	590,385.70CR	1,033,280.66CR	1,033,280.66CR
TOTAL EXPENDITURES		0.00	607,302.97	1,407,311.96	1,407,311.96
TOTAL FUND EQUITY		3,992,455.34CR	16,917.27	374,031.30	3,618,424.04CR
TOTAL LIABILITIES & EQUITY		6,980,378.85CR	296,590.53CR	148,140.60	6,832,238.25CR

UNAUDITED - 4/30/24

008-Sewer Fund

ACCT NO#	ACCOUNT NAME	BEGINNING BALANCE	M-T-D ACTIVITY	Y-T-D ACTIVITY	CURRENT BALANCE
ASSETS					
008.100.001.001	Dollar Bank SEWER	82,033.79	38,573.11CR	54,063.38CR	27,970.41
008.100.001.002	PNC PennVest	0.00	0.00	0.00	0.00
008.120.001.001	PLGIT	0.00	0.00	0.00	0.00
008.120.001.002	PLGIT Plus	0.00	0.00	0.00	0.00
008.120.001.003	Sewer Capital Bond	0.00	0.00	0.00	0.00
008.120.001.005	National City	0.00	0.00	0.00	0.00
008.120.001.006	Huntington	0.02CR	0.00	0.00	0.02CR
008.130.000.000	Due from Bond Fund	0.00	0.00	0.00	0.00
008.130.001.000	Due From General Fund	0.00	465.00	520.00	520.00
008.130.003.000	Due From Highway Aid	0.00	0.00	0.00	0.00
008.130.009.000	Due From Stormwater Fund	0.00	0.00	0.00	0.00
008.131.001.000	Misc. Receivable	12,004.29	0.00	0.00	12,004.29
008.145.000.000	Sewer Fees Receivable	945,186.49	0.00	0.00	945,186.49
008.146.000.000	Liened Sewer Accts	36,027.79	0.00	0.00	36,027.79
008.147.000.000	Reimbursement Receivable	100,000.00	0.00	0.00	100,000.00
008.147.001.000	Interest Receivable	0.00	0.00	0.00	0.00
008.147.002.000	Tap Fees Receivable	64,663.45	0.00	0.00	64,663.45
008.155.001.000	PENN Vest Loan Receivable	0.00	0.00	0.00	0.00
008.163.000.000	Accum. Depr	3,872,242.65CR	0.00	0.00	3,872,242.65CR
008.164.000.000	PP&E	11,804,618.61	0.00	0.00	11,804,618.61
008.164.003.000	EPA Consent Work	3,311,466.78	0.00	0.00	3,311,466.78
008.166.000.000	CIP	210,105.69	0.00	0.00	210,105.69
TOTAL ASSETS		12,693,864.22	38,108.11CR	53,543.38CR	12,640,320.84
LIABILITIES					
008.200.001.000	Vouchers Payable	1,277,743.19CR	0.00	0.00	1,277,743.19CR
008.201.001.000	Accrued Payroll	0.00	0.00	0.00	0.00
008.230.001.000	Due to General Fund	3,615,343.35CR	162,261.98CR	100,641.25	3,514,702.10CR
008.230.003.000	Due to Highway Aid	0.00	0.00	0.00	0.00
008.248.000.000	Lien Interest	10,184.34CR	0.00	0.00	10,184.34CR
008.248.001.001	Accrued Interest	0.00	0.00	0.00	0.00
008.249.000.001	Misc. Liabilities	0.00	0.00	0.00	0.00
008.255.000.000	PENN Vest Loan Receivable	0.00	0.00	0.00	0.00
008.255.000.001	2003 Bond Issue	0.00	0.00	0.00	0.00
008.255.000.002	PennVest Loan	0.50	0.00	0.00	0.50
008.255.000.003	Penn Vest 2009 Loan	0.03	0.00	0.00	0.03
008.255.000.004	2014 Bond Issue	0.00	0.00	0.00	0.00
008.255.000.005	Penn Vest Loan 2010	0.09	0.00	0.00	0.09
008.255.000.006	2018 Bond Issue	5,178,250.00CR	0.00	0.00	5,178,250.00CR
008.255.000.007	2019 Bond Issue	917,971.00 CR	0.00	0.00	917,971.00 CR
TOTAL LIABILITIES		10,999,491.26CR	162,261.98CR	100,641.25	10,898,850.01CR

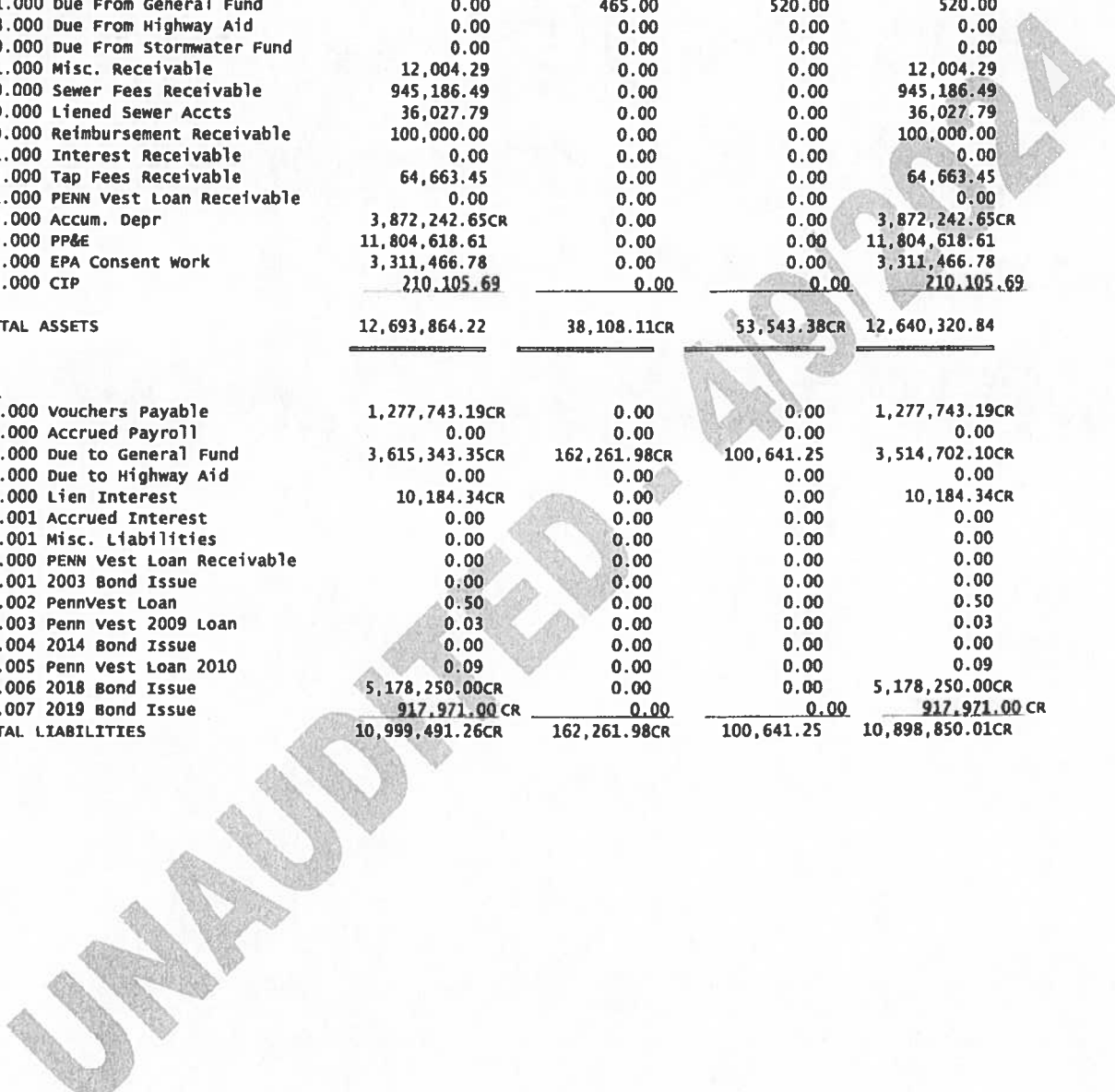

008-Sewer Fund

ACCT NO#	ACCOUNT NAME	BEGINNING BALANCE	M-T-D ACTIVITY	Y-T-D ACTIVITY	CURRENT BALANCE
FUND EQUITY					
008.279.002.000	Restricted	0.00	0.00	0.00	0.00
008.279.004.000	Assigned	0.00	0.00	0.00	0.00
008.279.005.000	Unassigned	0.00	0.00	0.00	0.00
008.289.000.000	Net Assets	1,694,372.96CR	0.00	0.00	1,694,372.96CR
TOTAL REVENUES		0.00	458,891.89CR	692,456.62CR	692,456.62CR
TOTAL EXPENDITURES		0.00	659,261.98	645,358.75	645,358.75
TOTAL FUND EQUITY		1,694,372.96CR	200,370.09	47,097.87CR	1,741,470.83CR
TOTAL LIABILITIES & EQUITY		12,693,864.22CR	38,108.11	53,543.38	12,640,320.84CR

UNAUDITED - 4/9/2024

009-Stormwater Fund

ACCT NO#	ACCOUNT NAME	BEGINNING BALANCE	M-T-D ACTIVITY	Y-T-D ACTIVITY	CURRENT BALANCE
ASSETS					
009.100.001.001	Cash	310,046.62	134,673.34	45,277.89CR	264,768.73
009.100.001.005	National City	0.00	0.00	0.00	0.00
009.100.001.006	Huntington	0.00	0.00	0.00	0.00
009.120.001.001	PLGIT	0.00	0.00	0.00	0.00
009.120.001.005	S&T Bank	0.00	0.00	0.00	0.00
009.120.001.006	S&T Bank	0.00	0.00	0.00	0.00
009.130.001.000	Due From General Fund	0.00	0.00	36,361.92	36,361.92
009.130.001.004	Due from American Rescue Plan	0.00	0.00	0.00	0.00
009.147.001.000	Storm Fees Receivable	108,608.35	0.00	0.00	108,608.35
009.147.002.000	Penalty and Interest Rec.	8,814.35	0.00	0.00	8,814.35
009.163.000.000	Accum. Depr.	1,320.00CR	0.00	0.00	1,320.00CR
009.164.000.000	PP&E	207,886.00	0.00	0.00	207,886.00
TOTAL ASSETS		634,035.32	134,673.34	8,915.97CR	625,119.35
LIABILITIES					
009.200.001.000	Account Payable	120,000.00CR	0.00	0.00	120,000.00CR
009.230.000.004	Due to American Rescue Fund	0.00	0.00	0.00	0.00
009.230.001.000	Due to General Fund	273,493.71CR	219,395.68	443,201.87	169,708.16
009.230.008.000	Due From Sewer	0.00	0.00	0.00	0.00
TOTAL LIABILITIES		393,493.71CR	219,395.68	443,201.87	49,708.16
FUND EQUITY					
009.279.000.000	Fund Balance	240,541.61CR	0.00	0.00	240,541.61CR
009.279.002.000	Restricted	0.00	0.00	0.00	0.00
009.279.004.000	Assigned	0.00	0.00	0.00	0.00
009.279.005.000	Unassigned	0.00	0.00	0.00	0.00
TOTAL REVENUES		0.00	384,635.11CR	531,576.17CR	531,576.17CR
TOTAL EXPENDITURES		0.00	30,566.09	97,290.27	97,290.27
TOTAL FUND EQUITY		240,541.61CR	354,069.02CR	434,285.90CR	674,827.51CR
TOTAL LIABILITIES & EQUITY		634,035.32CR	134,673.34CR	8,915.97	625,119.35CR

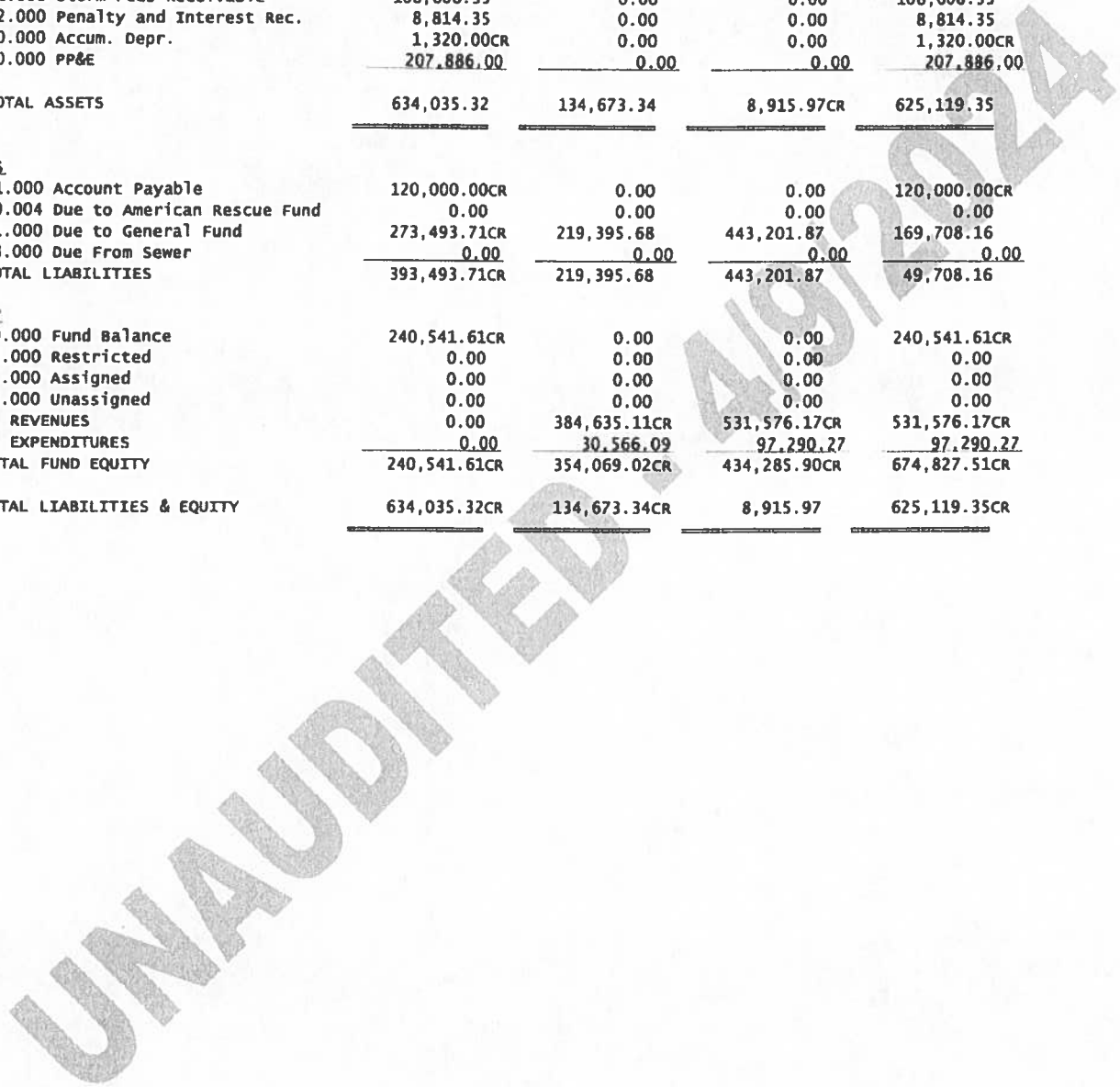

035-Highway Aid Fund

ACCT NO#	ACCOUNT NAME	BEGINNING BALANCE	M-T-D ACTIVITY	Y-T-D ACTIVITY	CURRENT BALANCE
ASSETS					
035.100.001.001	Cash	529,076.29	77,064.18CR	123,337.80CR	405,738.49
035.120.001.001	PLGIT HIGHWAY AID	0.00	0.00	0.00	0.00
035.120.001.005	S&T Bank	0.00	0.00	0.00	0.00
035.120.001.006	S&T Bank	0.00	0.00	0.00	0.00
035.130.000.001	Due from General Fund	0.00	0.00	0.00	0.00
035.147.001.000	Interest Receivable	0.00	0.00	0.00	0.00
TOTAL ASSETS		529,076.29	77,064.18CR	123,337.80CR	405,738.49
LIABILITIES					
035.200.001.000	Vouchers Payable	0.00	0.00	0.00	0.00
035.230.001.000	Due to General Fund	13,000.80CR	0.00	3,463.63CR	16,464.43CR
035.230.008.000	Due to Sewer Fund	0.00	0.00	0.00	0.00
TOTAL LIABILITIES		13,000.80CR	0.00	3,463.63CR	16,464.43CR
FUND EQUITY					
035.279.000.001	Unreserved Fund Balance	74,798.39CR	0.00	0.00	74,798.39CR
035.279.002.000	Restricted	441,277.10CR	0.00	0.00	441,277.10CR
035.279.003.000	Committed	0.00	0.00	0.00	0.00
035.279.004.000	Assigned	0.00	0.00	0.00	0.00
035.279.005.000	Unassigned	0.00	0.00	0.00	0.00
TOTAL REVENUES		0.00	2,274.58CR	4,050.86CR	4,050.86CR
TOTAL EXPENDITURES		0.00	79,338.76	130,852.29	130,852.29
TOTAL FUND EQUITY		516,075.49CR	77,064.18	126,801.43	389,274.06CR
TOTAL LIABILITIES & EQUITY		529,076.29CR	77,064.18	123,337.80	405,738.49CR

UNAUDITED - 4/3/2024

TOWNSHIP OF O'HARA
 STATEMENT OF REVENUES & EXPENDITURES - BUDGET VS. ACTUAL
 AS OF: FEBRUARY 29TH, 2024

FUND: 001-General Fund

	PRIOR YEAR ANNUAL	CURRENT BUDGET	MTD REV/EXP	YTD REV/EXP	% OF BUDGET	REMAINING BALANCE
REVENUES						
Real Property Taxes	8,410	2,714,843	4,810	12,894	0.47	2,701,949
Local Tax Enabling Act	782,221	4,962,200	486,833	804,039	16.20	4,158,161
Building/Structure	64,829	129,500	11,510	31,722	24.50	97,779
Bus. Licenses & Permits	49,200	200,000	47,905	47,905	23.95	152,095
Fines	6,187	28,500	1,590	2,471	8.67	26,029
Interest Earnings	14,925	85,500	9,053	14,906	17.43	70,594
Fed Cap & Oper Grants	1,153	2,500	0	0	0.00	2,500
St Cap & Oper Grants	147	217,203	0	0	0.00	217,203
St Shared Rev & Entitle	0	311,692	0	21,868	7.02	289,824
Local Gov Cap & Oper Gr	39,414	175,000	22,364	40,073	22.90	134,927
Charges for Services	1,024	34,350	450	48,038	139.85 (13,688)
Public Safety	4,110	25,000	405	405	1.62	24,595
Miscellaneous	16,912	234,000	5,466	8,960	3.83	225,040
TOTAL REVENUES	988,532	9,120,288	590,386	1,033,281	11.33	8,087,007
EXPENDITURES						
Governance	169,608	419,492	27,032	113,082	26.96	306,410
Finance	38,258	243,367	15,303	33,155	13.62	210,212
Taxation	3,169	138,065	1,791	3,237	2.34	134,828
Legal	6,758	133,000	2,075	8,887	6.68	124,113
Engineering	11,862	80,175	5,742	12,766	15.92	67,409
Police	388,211	2,511,193	176,199	375,095	14.94	2,136,098
Fire	65,126	453,953	41,073	153,430	33.80	300,523
Ambulance	8,682	59,550	0	7,943	13.34	51,607
Code Enforcement	36,813	207,740	5,127	24,624	11.85	183,116
Planning and Zoning	15,250	100,644	7,189	15,742	15.64	84,902
Emergency Management	0	2,500	0	0	0.00	2,500
Crossing Guards	870	5,500	235	555	10.09	4,945
Human Services	16,943	106,692	7,764	16,902	15.84	89,790
Solid Waste Collection	87,018	1,502,177	116,183	229,578	15.28	1,272,599
Building	56,876	197,872	16,129	31,650	16.00	166,222
Street Lighting	5,958	0	72	95	0.00 (95)
Repairs	61,248	325,157	26,418	52,973	16.29	272,184
Maintenance /Road Repairs	190,321	965,404	40,920	156,501	16.21	808,903
Parks	68,367	568,959	28,800	73,096	12.85	495,863
Community Center	42,000	142,000	10,000	20,000	14.08	122,000
Debt Principal	0	211,150	0	0	0.00	211,150
Debt Interest	0	96,896	0	0	0.00	96,896
Pension	0	156,540	0	0	0.00	156,540
Capital Items	167,731	2,140,911	79,252	78,002	3.64	2,062,909
Transfers To Other Funds	0	0	0	0	0.00	0
Extraordinary Event	975	0	0	0	0.00	0
TOTAL EXPENDITURES	1,442,046	10,768,937	607,303	1,407,312	13.07	9,361,625
REVENUE OVER/(UNDER) EXPENDITURES	(453,514)	(1,648,649)	(16,917)	(374,031)	22.69 (1,274,618)

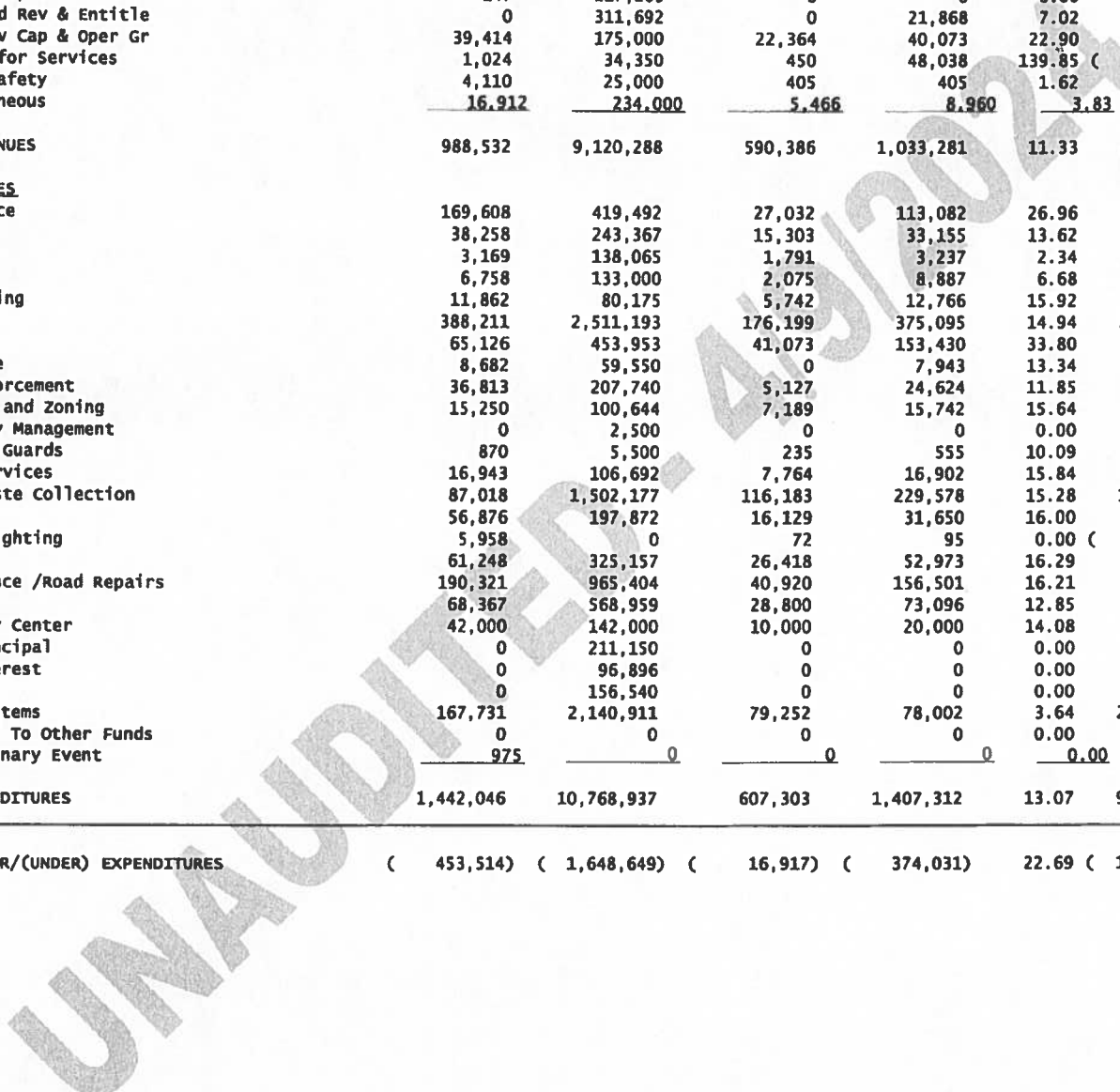

TOWNSHIP OF O'HARA
 STATEMENT OF REVENUES & EXPENDITURES - BUDGET vs. ACTUAL
 AS OF: FEBRUARY 29TH, 2024

FUND: 008-Sewer Fund

	PRIOR YEAR ANNUAL	CURRENT BUDGET	MTD REV/EXP	YTD REV/EXP	% OF BUDGET	REMAINING BALANCE
REVENUES						
Building/Structure	385	4,500	440	605	13.44	3,895
Interest Earnings	2,470	6,000	103	152	2.53	5,848
St Shared Rev & Entitle	0	100,000	0	0	0.00	100,000
Miscellaneous	<u>702,113</u>	<u>3,387,412</u>	<u>458,349</u>	<u>691,700</u>	<u>20.42</u>	<u>2,695,712</u>
TOTAL REVENUES	704,968	3,497,912	458,892	692,457	19.80	2,805,455
EXPENDITURES						
Sewer	820,997	4,128,075	659,262	645,359	15.63	3,482,716
Perm. Transfers	<u>0</u>	<u>25,000</u>	<u>0</u>	<u>0</u>	<u>0.00</u>	<u>25,000</u>
TOTAL EXPENDITURES	820,997	4,153,075	659,262	645,359	15.54	3,507,716
REVENUE OVER/(UNDER) EXPENDITURES	(116,029)	(655,163)	(200,370)	47,098	7.19-	(702,261)

UNAUDITED - 4/9/2024

TOWNSHIP OF O'HARA
STATEMENT OF REVENUES & EXPENDITURES - BUDGET vs. ACTUAL
AS OF: FEBRUARY 29TH, 2024

FUND: 009-Stormwater Fund

	PRIOR YEAR ANNUAL	CURRENT BUDGET	MTD REV/EXP	YTD REV/EXP	% OF BUDGET	REMAINING BALANCE
REVENUES						
Interest Earnings	3,600	18,000	1,251	1,746	9.70	16,254
Miscellaneous	<u>602,232</u>	<u>881,500</u>	<u>383,384</u>	<u>529,830</u>	<u>60.11</u>	<u>351,670</u>
TOTAL REVENUES	605,833	899,500	384,635	531,576	59.10	367,924
EXPENDITURES						
Tax Collection	5,665	22,500	2,407	3,113	13.83	19,387
Stormwater	62,490	439,020	14,945	71,832	16.36	367,188
Capital item	<u>3,104</u>	<u>369,150</u>	<u>13,214</u>	<u>13,214</u>	<u>3.58</u>	<u>355,936</u>
TOTAL EXPENDITURES	71,259	830,670	30,566	88,158	10.61	742,512
REVENUE OVER/(UNDER) EXPENDITURES	534,574	68,830	354,069	443,418	644.22 (374,588)

UNAUDITED - 4/9/2024

TOWNSHIP OF O'HARA
 STATEMENT OF REVENUES & EXPENDITURES - BUDGET vs. ACTUAL
 AS OF: FEBRUARY 29TH, 2024

FUND: 035-Highway Aid Fund

	PRIOR YEAR ANNUAL	CURRENT BUDGET	MTD REV/EXP	YTD REV/EXP	% OF BUDGET	REMAINING BALANCE
REVENUES						
Interest Earnings	3,189	20,000	2,275	4,051	20.25	15,949
Fed Cap & Oper Grants	0	290,995	0	0	0.00	290,995
Miscellaneous	0	0	0	0	0.00	0
TOTAL REVENUES	3,189	310,995	2,275	4,051	1.30	306,944
EXPENDITURES						
Snow and Ice Removal	49,107	225,000	57,628	103,138	45.84	121,862
Street Lighting	16,663	70,000	6,004	12,007	17.15	57,993
TOTAL EXPENDITURES	65,769	295,000	63,632	115,146	39.03	179,854
REVENUE OVER/(UNDER) EXPENDITURES	(62,581)	15,995	(61,358)	(111,095)	694.56-	127,090

UNAUDITED - 4/9/2024

VENDOR SET: 01 Township of O'Hara
 BANK: 002 Dollar Bank
 DATE RANGE: 3/13/2024 THRU 4/09/2024

VENDOR I.D.	NAME	STATUS	CHECK DATE	INVOICE AMOUNT	DISCOUNT	CHECK NO	CHECK STATUS	CHECK AMOUNT
00973	Access I-10780530 Filing fees	R	3/20/2024	410.29		047856		410.29
01165	Amazon Capital Services							
	I-1&43-3Q1G-PL1X Lock box	R	3/20/2024	21.99		047857		
	I-1DW9-TLK7-H7XJ Lamp, microwave	R	3/20/2024	308.38		047857		
	I-1G9M-WRQH-41MV wireless doorbell	R	3/20/2024	14.21		047857		
	I-1NPF-6DTN-6MH9 Printer/warranty	R	3/20/2024	801.96		047857		
	I-1T43-3Q1G-37D1 Reflective safety tape	R	3/20/2024	29.97		047857		1,176.51
00786	Butler Gas Products Company I-922772 Aceytene etc	R	3/20/2024	75.79		047858		75.79
00712	CenturyLink I-68026774 Telephone	R	3/20/2024	18.57		047859		18.57
00148	Comcast I-5154 3/24 Telephone	R	3/20/2024	66.12		047860		66.12
00556	Comdoc, Inc I-IN6150206 Copies B & W , color	R	3/20/2024	135.97		047861		135.97
00086	Duquesne Light Company							
	I-230-3/24 Traffic lights	R	3/20/2024	587.17		047862		
	I-630-3/24 Electric service	R	3/20/2024	4,057.85		047862		
	I-760 3/24 Street lights	R	3/20/2024	6,028.26		047862		10,673.28
00774	Galls, LLC							
	I-027129032 Uniform allowoance/Benegi	R	3/20/2024	52.36		047863		
	I-027182934 Uniform allowance	R	3/20/2024	145.73		047863		
	I-0272074 Uniform allowance	R	3/20/2024	109.26		047863		307.35
01359	Pennsylvania State University I-288723 Penn State class Benegi & Hill	R	3/20/2024	1,628.00		047864		1,628.00
00076	Professional Code Services Inc I-202403205916 Bldg & Elec inspectins	R	3/20/2024	7,920.00		047865		7,920.00
00122	Quill I-73758447 Copier toners	R	3/20/2024	639.82		047866		639.82
00139	Staples							
	I-6000508904* Toner, foil seals, cert holder	R	3/20/2024	155.59		047867		
	I-6000508905 Bath tissue	R	3/20/2024	131.67		047867		
	I-6000508906 Expending files	R	3/20/2024	153.50		047867		440.76

VOUCHERS PENDING APPROVAL - 4/9/2024

ENDOR SET: 01 Township of O'Hara
ANK: 002 Dollar Bank
ATE RANGE: 3/13/2024 THRU 4/09/2024

ENDOR I.D.	NAME	STATUS	CHECK DATE	INVOICE AMOUNT	DISCOUNT	CHECK NO	CHECK STATUS	CHECK AMOUNT
0107	Verizon							
I-1-26 3/24	Telephone	R	3/20/2024	37.94		047868		
I-1-82 3/24	Telephone	R	3/20/2024	42.10		047868		
I-1-86 3/24	Telephone	R	3/20/2024	83.85		047868		163.89
0320	Wilmington Trust							
I-20231130-104846-A*	Admin/Agent fee	R	3/20/2024	780.00		047869		
I-20231130-86390-A*	Admin/Agent fee	R	3/20/2024	780.00		047869		1,560.00
1346	Xerox Financial Services							
I-5475582	Copier	R	3/20/2024	406.83		047870		406.83
1258	Jay Davis							
I-63513827	PELRAS Conference/milage	R	3/20/2024	1,184.39		047871		1,184.39
10107	Verizon							
I-1-69 3/24	Telephone	R	3/20/2024	43.98		047872		43.98
1361	Stone Age Games Inc							
I-202403225918	Box Hockey set	R	3/22/2024	8,428.00		047873		8,428.00
10148	Comcast							
I-8871-3/24	Telephone	R	3/22/2024	295.38		047874		295.38
1120	Hampton Shaler water Authority							
I-202403225921	Sacco Park	R	3/22/2024	20.00		047875		
I-202403225922	Villa Dr	R	3/22/2024	20.00		047875		40.00
10891	Peoples							
I-202403225919	Gas service/storage shed	R	3/22/2024	107.62		047876		
I-202403225920	Gas service/Muni bldg	R	3/22/2024	411.42		047876		519.04
1343	All Phase 11 Site Contracting							
I-23-SW1	Rowers Run restoration project	R	4/09/2024	210,000.00		047877		210,000.00
10823	All Time Truck & Car Service							
I-33234	State inspection truck 13	R	4/09/2024	114.00		047878		
I-33279	State inspection/trailer	R	4/09/2024	64.00		047878		178.00
10551	Allegheny Fence Construction C							
I-24-03-29DA	Transmitter for Muni bld gate	R	4/09/2024	440.00		047879		440.00
1165	Amazon Capital Services							
I-14T1-3M4Q-MYQ6	HDMI cable	R	4/09/2024	6.92		047880		
I-16D6-GT9P-1X4J	Patch cables, card reader	R	4/09/2024	204.05		047880		
I-177K-4Q7L-GNG6	File cabinet	R	4/09/2024	109.99		047880		
I-1C63-6CPH-3N1J	Headphones	R	4/09/2024	28.95		047880		
I-1FPP-VYDG-CCNY	Flash drive	R	4/09/2024	39.98		047880		

VOUCHERS PENDING APPROVAL - 4/9/2024

VENDOR SET: 01 Township of O'Hara
 BANK: 002 Dollar Bank
 DATE RANGE: 3/13/2024 THRU 4/09/2024

VENDOR I.D.	NAME	STATUS	CHECK DATE	INVOICE AMOUNT	DISCOUNT	CHECK NO	CHECK STATUS	CHECK AMOUNT
I-1HX9-PP7Y-CNLX	Printer	R	4/09/2024	449.99		047880		
I-1M1L-YRLR-91YX	Pond fountain	R	4/09/2024	1,246.16		047880		
I-1TQ6-DJCF-7LRF	Microphone, pens, calc paper,	R	4/09/2024	104.85		047880		
I-1YD7-L3LW-3N1H	Computer mouse	R	4/09/2024	10.99		047880		2,201.88
00900	Amerikohl Aggregates, Inc.							
I-70266	2 Loads 2 A stone	R	4/09/2024	577.72		047881		
I-70389	2A stone	R	4/09/2024	308.98		047881		886.70
00810	Amerikohl Transport Inc.							
I-45550	Trucking fee	R	4/09/2024	533.32		047882		
I-45624	Trucking fee	R	4/09/2024	253.81		047882		787.13
01308	APLS Inc							
I-0000034074	Grass seed	R	4/09/2024	153.00		047883		153.00
01035	Aramark Uniform Services							
I-303.0130367	Rug service/Mechanic towels	R	4/09/2024	267.51		047884		
I-3030131374	Rug service/Mechanic towels	R	4/09/2024	267.51		047884		
I-3030132372	Rug service/Mechanic towels	R	4/09/2024	267.51		047884		
I-3030133362	Rug service/Mechanic towels	R	4/09/2024	267.51		047884		
I-3030134326	Rug service/Mechanic towels	R	4/09/2024	263.85		047884		1,333.89
00714	Aspinwall VFD							
I-202404025934	Municipal subsidy	R	4/09/2024	5,727.14		047885		5,727.14
01364	Automation Aids, Inc							
I-202404035940	File drawer	R	4/09/2024	2,864.91		047886		2,864.91
01199	Bear Playgrounds							
I-1544	Playground mulch	R	4/09/2024	1,325.00		047887		1,325.00
01006	BearCom Inc.							
I-5698117	Maintenance agreement	R	4/09/2024	126.00		047888		
I-5698123	Repeater service	R	4/09/2024	456.00		047888		582.00
00715	Blawnox VFD							
I-202404025935	Municipal subsidy	R	4/09/2024	5,648.43		047889		5,648.43
01061	Bruce & Merrilees Electric Com							
I-14853	Replace LED bulbs Fox Chapel	R	4/09/2024	960.00		047890		960.00
00093	Catherine L Bubas							
I-202404035941	Reuimb get well/Anna Maria	R	4/09/2024	53.45		047891		53.45

VOUCHERS PENDING APPROVAL - 4/18/2024

ENDOR SET: 01 Township of O'Hara
ANK: 002 Dollar Bank
DATE RANGE: 3/13/2024 THRU 4/09/2024

ENDOR I.D.	NAME	STATUS	CHECK DATE	INVOICE AMOUNT	DISCOUNT	CHECK NO	CHECK STATUS	CHECK AMOUNT
0030	Buchanan Ingersoll & Rooney PC							
I-12292703	Legal services	R	4/09/2024	10,827.50		047892		10,827.50
0195	Building Products Inc							
I-419478	Park supplies	R	4/09/2024	46.95		047893		
I-420045	Straw for parks	R	4/09/2024	35.00		047893		
I-421998	Sand/cement	R	4/09/2024	82.30		047893		164.25
1362	Butler Floor & Carpet							
I-8797	Flooring/Police station	R	4/09/2024	2,315.30		047894		2,315.30
1329	Campbell Durrant, P.C.							
I-79220	Legal services	R	4/09/2024	1,665.93		047895		1,665.93
1322	Chemsearchfe							
I-8616022	Odor control pump station	R	4/09/2024	390.00		047896		390.00
1334	Citco Water							
I-s100249618.001	36" pipe Ravine St	R	4/09/2024	2,100.00		047897		2,100.00
1344	Custom Products Corporation							
I-INV4889	No parking on grass signs	R	4/09/2024	101.35		047898		
I-INV5176	Dog poo signs	R	4/09/2024	102.09		047898		203.44
1170	David Davis Communications, In							
I-60794	2 New phones/balance	R	4/09/2024	440.00		047899		
I-61063	Qtr ESI program	R	4/09/2024	615.00		047899		1,055.00
1205	Dollar Bank							
I-112183	Telephone	R	4/09/2024	252.31		047900		
I-JBNSQVZY36	Conference	R	4/09/2024	150.00		047900		402.31
0086	Duquesne Light Company							
I-767-3/24	Elec service/chargers	R	4/09/2024	273.88		047901		273.88
0085	Employment Partners Benefits F							
I-102212	Employee health & welfare	R	4/09/2024	882.70		047902		882.70
0675	Environmental Systems Research							
I-94687512	Arcgis online	R	4/09/2024	538.00		047903		538.00
1294	Export Fuel Co Inc							
I-247499	Tank rental	R	4/09/2024	250.00		047904		250.00

VOUCHERS PENDING APPROVAL - 4/9/2024

VENDOR SET: 01 Township of O'Hara
 BANK: 002 Dollar Bank
 DATE RANGE: 3/13/2024 THRU 4/09/2024

VENDOR I.D.	NAME	STATUS	CHECK DATE	INVOICE AMOUNT	DISCOUNT	CHECK NO	CHECK STATUS	CHECK AMOUNT
11250	Fleet Pride Inc							
I-PIT012199	Rear springs truck 13	R	4/09/2024	1,898.06		047905		1,898.06
11197	Ford Office Technologies							
I-625192	Computer consulting	R	4/09/2024	590.00		047906		
I-626288	Computer consulting	R	4/09/2024	1,166.00		047906		1,756.00
10078	Fox Chapel Authority							
I-202404025929	Park restroom	R	4/09/2024	54.59		047907		
I-202404025930	Muni bldg	R	4/09/2024	312.82		047907		
I-202404025931	Park restroom	R	4/09/2024	32.96		047907		400.37
10203	Fox Chapel Borough							
I-202403145912	Transportation fee	R	4/09/2024	32,020.00		047908		32,020.00
10716	Fox Chapel VFD							
I-202404025936	Municipal subsidy	R	4/09/2024	4,021.74		047909		4,021.74
10774	Galls, LLC							
I-02379971	Parts for gun order	R	4/09/2024	1,909.70		047910		
I-027247708	GN box evidence	R	4/09/2024	122.06		047910		
I-027303268	Uniform allowance/Hill	R	4/09/2024	265.31		047910		
I-027358393	2 Hand gun boxes	R	4/09/2024	127.88		047910		
I-027380581	Uniform allowance/Lynn	R	4/09/2024	38.44		047910		
I-02791819	Uniform allowance/Lynn	R	4/09/2024	110.67		047910		
I-02791821	2 Tourniquets	R	4/09/2024	68.86		047910		2,642.92
10950	Geese Police of Western PA							
I-2108	Geese removal	R	4/09/2024	2,100.00		047911		2,100.00
11357	Geissele Automatics							
I-21908	Super duty rifle sys	R	4/09/2024	19,900.00		047912		19,900.00
10372	Govconnection Inc							
I-75136264	Universal USB dock	R	4/09/2024	229.59		047913		229.59
10010	Grainger							
I-9041557092	Sign hardware	R	4/09/2024	24.04		047914		
I-9041557100	Sign hardware	R	4/09/2024	63.42		047914		
I-9045839702	Lifting slings	R	4/09/2024	66.48		047914		153.94
10035	Guttman Energy Inc.							
I-F66088589	Fuel purchases	R	4/09/2024	1,411.37		047915		
I-F66112673	Fuel purchases	R	4/09/2024	574.59		047915		
I-F66139365	Fuel purchases	R	4/09/2024	3,044.47		047915		
I-F66161881	Fuel purchases	R	4/09/2024	1,326.82		047915		6,357.25

VOUCHERS PENDING APPROVAL - 4/9/2024

7/07/2024 10:30 AM
 ENDOR SET: 01 Township of O'Hara
 ANK: 002 Dollar Bank
 DATE RANGE: 3/13/2024 THRU 4/09/2024

BY HISTORY CHECK REPORT

ENDOR I.D.	NAME	STATUS	CHECK DATE	INVOICE AMOUNT	DISCOUNT	CHECK NO	CHECK STATUS	CHECK AMOUNT
0087 I-OH2024-03	Hampton Shaler Water Authority Sewer billing	R	4/09/2024	1,445.43		047916		1,445.43
1120 I-202404025932	Hampton Shaler Water Authority Sax Blvd	R	4/09/2024	20.00		047917		20.00
1234 I-52875	Hi Tech Auto Care State inspection	R	4/09/2024	55.33		047918		55.33
1232 I-X105018493:02 I-X105018493:03 I-X105018626:01 I-Z1050189493:01	Hill International Trucks, LLC Filters/stock Fuel/filter kit DEF Sensor Filters/stock	R R R R	4/09/2024 4/09/2024 4/09/2024 4/09/2024	109.98 43.00 194.94 77.28		047919 047919 047919 047919		425.20
0752 I-202404015927	Hoffman Kennels, Inc. Animal control	R	4/09/2024	320.00		047920		320.00
1119 I-3142024	HTM Designs Military banners	R	4/09/2024	180.00		047921		180.00
1277 I-25997	James Giammatteo Reuimb SLF class	R	4/09/2024	32.56		047922		32.56
10398 I-3-C-#132 I-3-C-#134 I-3-C-#22 I-3-c-#23	Jordan Tax Service Inc LST comm Strm Wtr comm R/E comm Strm Wtr comm	R R R R	4/09/2024 4/09/2024 4/09/2024 4/09/2024	1,428.58 7,660.04 800.91 998.91		047923 047923 047923 047923		10,888.44
10706 I-1052-7 I-10594-46 I-10594-47 I-10604-17	Kress Tire Company Tires pars truck Tires & studs # 13 Rear tires old backhoe Mount & dismount tires truck16	R R R R	4/09/2024 4/09/2024 4/09/2024 4/09/2024	412.00 1,300.00 1,850.00 140.00		047924 047924 047924 047924		3,702.00
10092 I-9311399999	Lawson Products Inc Marking paint/wipes	R	4/09/2024	1,106.25		047925		1,106.25
10015 I-213087970 I-233407449 I-24578996 I-268150647 I-269334872 I-327302506 I-341755574 I-363607355	Lowe's Window blind/Police station SLF Traps SLF Traps Police material/small tools Pallet of sakcrete Gorilla tape CC Signs Tie wipes SLF traps	R R R R R R R R	4/09/2024 4/09/2024 4/09/2024 4/09/2024 4/09/2024 4/09/2024 4/09/2024 4/09/2024	9.01 9.48 6.63 854.43 231.58 9.48 27.98 23.20		047926 047926 047926 047926 047926 047926 047926 047926		

VOUCHERS PENDING APPROVAL - 4/9/2024

VENDOR SET: 01 Township of O'Hara
 BANK: 002 Dollar Bank
 DATE RANGE: 3/13/2024 THRU 4/09/2024

VENDOR I.D.	NAME	STATUS	CHECK DATE	INVOICE AMOUNT	DISCOUNT	CHECK NO	CHECK STATUS	CHECK AMOUNT
I-428916934	SLF Traps	R	4/09/2024	20.38		047926		
I-495224664	Material/Police station	R	4/09/2024	26.45		047926		
I-595576061	SLF traps material	R	4/09/2024	158.17		047926		
I-883345904	Deer fencing, shelves	R	4/09/2024	795.06		047926		2,171.85
10080	Maher Duessel							
I-1102586	2023 Twp audit	R	4/09/2024	12,000.00		047927		12,000.00
11046	Mahoney Cleaning Services LLC							
I-16944	Custodial services	R	4/09/2024	990.00		047928		990.00
11315	McCandless Ford							
I-202404045943	2024 F 550	R	4/09/2024	67,226.00		047929		67,226.00
11224	Michael Brothers Hauling, Inc.							
I-3401980	Glass recycling	R	4/09/2024	400.00		047930		400.00
10489	Napa Auto and Truck							
I-373983	Oil filter	R	4/09/2024	10.72		047931		
I-373984	Oil filters	R	4/09/2024	49.16		047931		
I-374276	Pol filter/brake parts	R	4/09/2024	109.84		047931		
I-374420	Oil filter	R	4/09/2024	66.38		047931		236.10
10217	North Hills Council of Governm							
I-213	Dues for SRT	R	4/09/2024	3,213.00		047932		3,213.00
10533	PA Dept of Labor & Industry-B							
I-1214619	Boiler inspection certificate	R	4/09/2024	87.21		047933		87.21
10226	Parkview VFD							
I-202404025938	Municipal subsidy	R	4/09/2024	18,750.00		047934		18,750.00
10058	Pestco							
I-694361	Air fresheners	R	4/09/2024	12.71		047935		12.71
10883	Pittsburgh Water Cooler Servic							
I-53910	Replace Elkay water cartridge	R	4/09/2024	243.99		047936		243.99
10321	Pleasant Valley VFD							
I-202404025939	Municipal subsidy	R	4/09/2024	18,750.00		047937		18,750.00
10019	Point Spring & Driveshaft Co							
I-1-INV-16961	Stock/brake drums	R	4/09/2024	856.18		047938		
I-1-INV-17023	Point Spring & Driveshaft Co	R	4/09/2024	199.98		047938		1,056.16

VOUCHERS PENDING APPROVAL - 4/12/2024

7/07/2024 10:50 AM
 ENDOR SET: 01 Township of O'Hara
 BANK: 002 Dollar Bank
 DATE RANGE: 3/13/2024 THRU 4/09/2024

ENDOR I.D.	NAME	STATUS	CHECK DATE	INVOICE AMOUNT	DISCOUNT	CHECK NO	CHECK STATUS	CHECK AMOUNT
0075 I-55294	Print Tech of Western PA LLC Newsletter	R	4/09/2024	3,601.30		047939		3,601.30
0076 I-202404035942	Professional Code Services Inc Bldg & elec inspections	R	4/09/2024	10,448.00		047940		10,448.00
0540 I-144961	ProPet Distributers Inc Doggy waste bags	R	4/09/2024	610.50		047941		610.50
1326 I-10533	PumpMan Pittsburgh LLC Valve for pump station	R	4/09/2024	4,219.29		047942		4,219.29
1154 I-31234639	Quadient Finance USA, Inc. Postage	R	4/09/2024	1,000.00		047943		1,000.00
1149 I-202404015926	Quadient Leasing USA, Inc. Mailing machine lease	R	4/09/2024	518.10		047944		518.10
0122 I-37549136 I-37598553	Quill Chairs & floor mats wall clock	R R	4/09/2024 4/09/2024	556.96 28.98		047945 047945		585.94
1145 I-14216	S & D Calibration Services Accutrak cert	R	4/09/2024	288.00		047946		288.00
1351 I-1740	Schultz Ornamental Iron Powder coating	R	4/09/2024	800.00		047947		800.00
10717 I-202404025937	Sharpsburg VFD Municipal subsidy	R	4/09/2024	3,352.70		047948		3,352.70
1363 I-138560730-001	SiteOne Landscape Supply, LLC Compost landscape	R	4/09/2024	504.85		047949		504.85
10324 I-202404025933	David M Smith Uniform allowance/Smith	R	4/09/2024	219.81		047950		219.81
10912 I-202403135911	Snap-On Tools Software subscription	R	4/09/2024	50.06		047951		50.06
10158 I-8607	Snider Recreation Inc. Pickleball nets	R	4/09/2024	1,967.00		047952		1,967.00

VOUCHERS PENDING APPROVAL - 4/9/2024

VENDOR SET: 01 Township of O'Hara
 BANK: 002 Dollar Bank
 DATE RANGE: 3/13/2024 THRU 4/09/2024

VENDOR I.D.	NAME	STATUS	CHECK DATE	INVOICE AMOUNT	DISCOUNT	CHECK NO	CHECK STATUS	CHECK AMOUNT
00877 I-1369140	Snyder Brothers Inc. Gas service/garage	R	4/09/2024	586.87		047953		586.87
00300 I-14150	Starr Image Products Copier/scanner rental	R	4/09/2024	335.00		047954		335.00
00785 I-202403265924	State Workers' Insurance Fund VFD workers comp	R	4/09/2024	1,317.00		047955		1,317.00
01242 I-3182	Steel City Drones LLC Portable command station	R	4/09/2024	5,049.00		047956		5,049.00
01065 I-202403195915	Stephenson Equipment, Inc. Rogers Tag21XL trailer	R	4/09/2024	46,483.47		047957		46,483.47
01358 I-102978 I-A103353	Team Nuts LLC Truck upfit Vinyl prints Admin cars	R R	4/09/2024 4/09/2024	3,215.30 225.00		047958 047958		3,440.30
00110 I-2469417	Trib Total Media Inc Legal notice Ordinance 1422	R	4/09/2024	44.20		047959		44.20
00084 I-0117288-0067-0	Waste Management Solid waste collection	R	4/09/2024	112,910.00		047960		112,910.00
00191 I-202403145913	Lauri Ann West Community Cente Municipal subsidy	R	4/09/2024	10,000.00		047961		10,000.00
00136 I-QUO147637	Witmer Public Safety Group Inc Night vision & red dot sights	R	4/09/2024	7,271.74		047962		7,271.74
01020 I-202403205917 I-202403285925	Benjamin C wolfson Court parking Court parking	R R	4/09/2024 4/09/2024	24.00 24.00		047963 047963		48.00
00152 I-21-02-4469-1056 I-24-02-4100-1065	David E Wooster & Associates I Traffic Engineering service Traffic Enginnering service	R R	4/09/2024 4/09/2024	97.50 716.00		047964 047964		813.50

VOUCHERS PENDING APPROVAL - 4/9/2024

1/09/2024 10:30 AM
 VENDOR SET: 01 Township of O'Hara
 BANK: 002 Dollar Bank
 DATE RANGE: 3/13/2024 THRU 4/09/2024

REPORT CHECK REPORT

VENDOR I.D.	NAME	STATUS	CHECK DATE	INVOICE AMOUNT	DISCOUNT	CHECK NO	CHECK STATUS	CHECK AMOUNT
-------------	------	--------	------------	----------------	----------	----------	--------------	--------------

* * T O T A L S * *		NO	INVOICE AMOUNT	DISCOUNTS	CHECK AMOUNT
REGULAR CHECKS:		109	721,600.54	0.00	721,600.54
HAND CHECKS:		0	0.00	0.00	0.00
DRAFTS:		0	0.00	0.00	0.00
EFT:		0	0.00	0.00	0.00
NON CHECKS:		0	0.00	0.00	0.00
VOID CHECKS:	0 VOID DEBITS		0.00		
	VOID CREDITS		0.00	0.00	0.00

TOTAL ERRORS: 0

VENDOR SET: 01	BANK: 002	TOTALS:	NO	INVOICE AMOUNT	DISCOUNTS	CHECK AMOUNT
			109	721,600.54	0.00	721,600.54
BANK: 002		TOTALS:	109	721,600.54	0.00	721,600.54
REPORT TOTALS:			109	721,600.54	0.00	721,600.54

VOUCHERS PENDING APPROVAL - 4/9/2024

SELECTION CRITERIA

ENDOR SET: 01-O'Hara Township
ENDOR: ALL
BANK CODES: Include: 002
FUNDS: All

CHECK SELECTION

CHECK RANGE: 000000 THRU 999999
DATE RANGE: 3/13/2024 THRU 4/09/2024
CHECK AMOUNT RANGE: 0.00 THRU 999,999,999.99
INCLUDE ALL VOIDS: YES

PRINT OPTIONS

SEQUENCE: CHECK NUMBER

PRINT TRANSACTIONS: YES
PRINT G/L: NO
UNPOSTED ONLY: NO
EXCLUDE UNPOSTED: NO
MANUAL ONLY: NO
SUB COMMENTS: NO
REPORT FOOTER: NO
CHECK STATUS: NO
PRINT STATUS: * - All

VOUCHERS PENDING APPROVAL - 4/9/2024

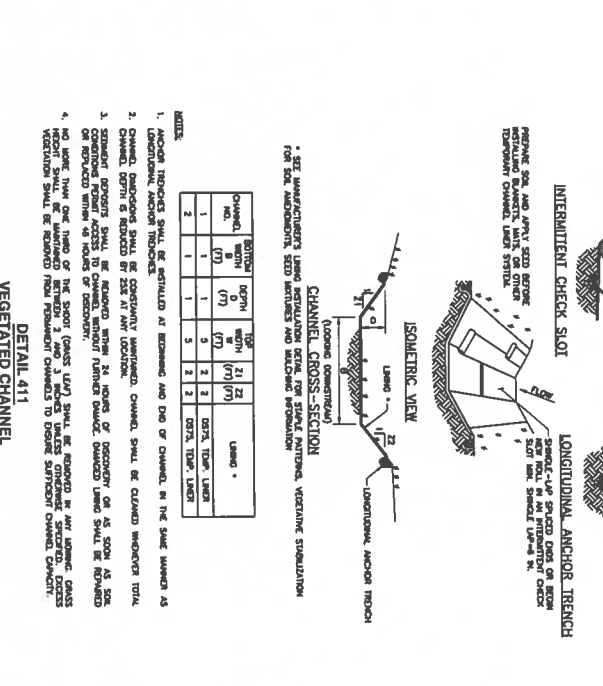
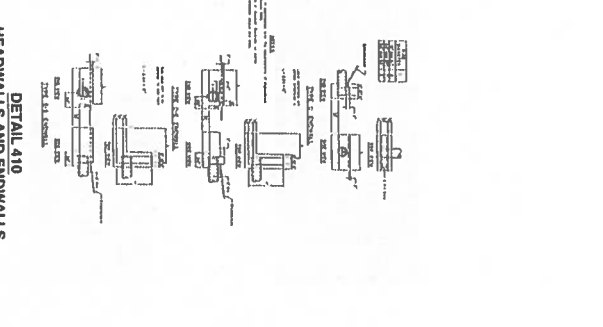
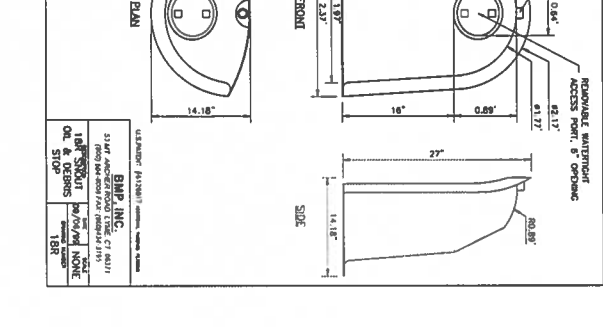
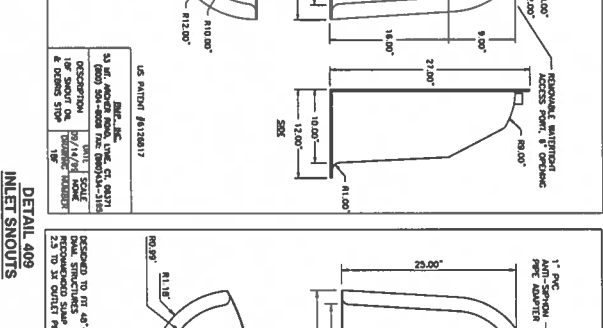
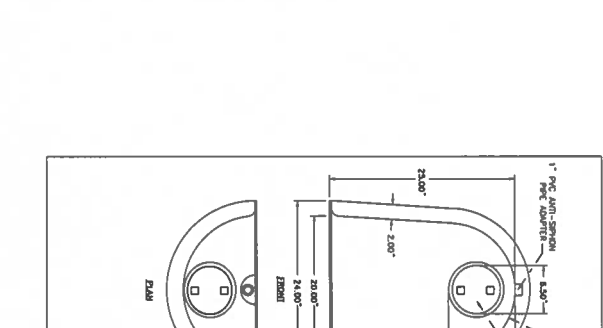
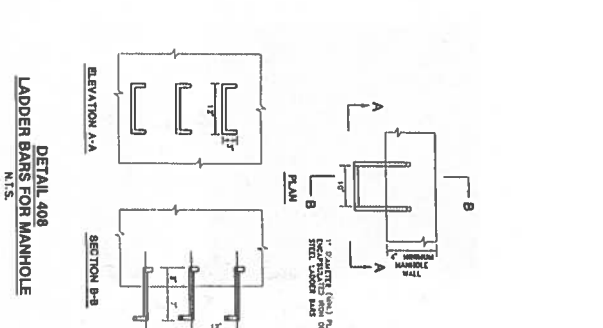
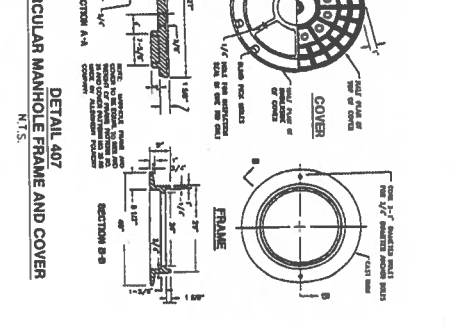
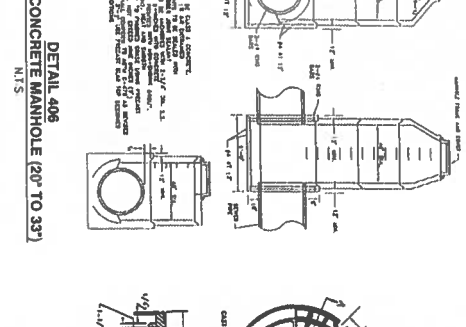
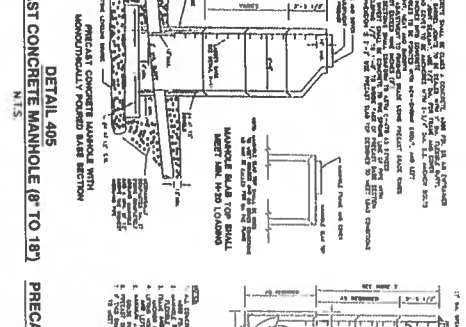
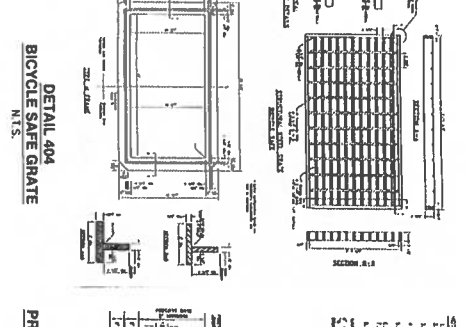
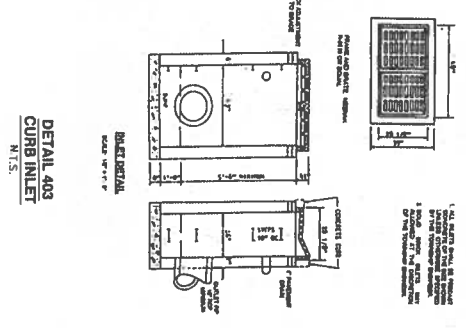
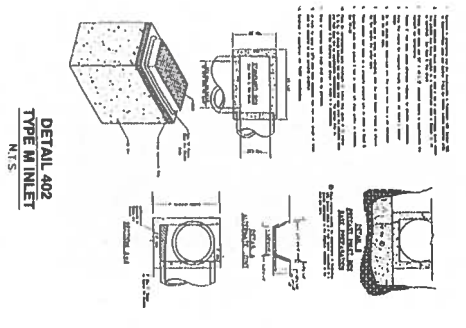
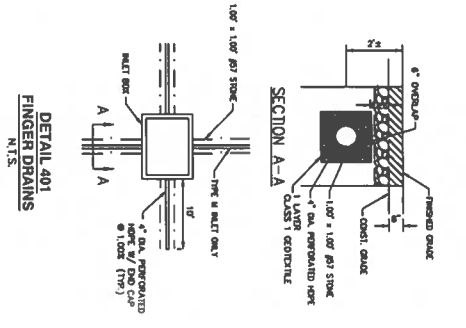

STANDARD PRECAST TYPE 4 MET BOX (6 FT X 4 FT)

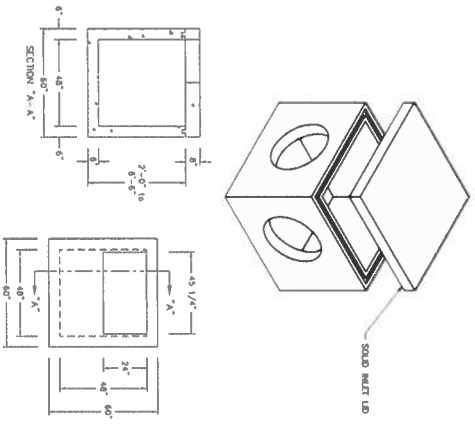

AND STORMWATER TO UNDERGROUND
RETENTION/TREATMENT SYSTEM SHALL BE
STANDARD PRECAST TYPE 4 MET BOXES
PROVIDED WITH CERTIFIED FIBER
AND CONNECTION.

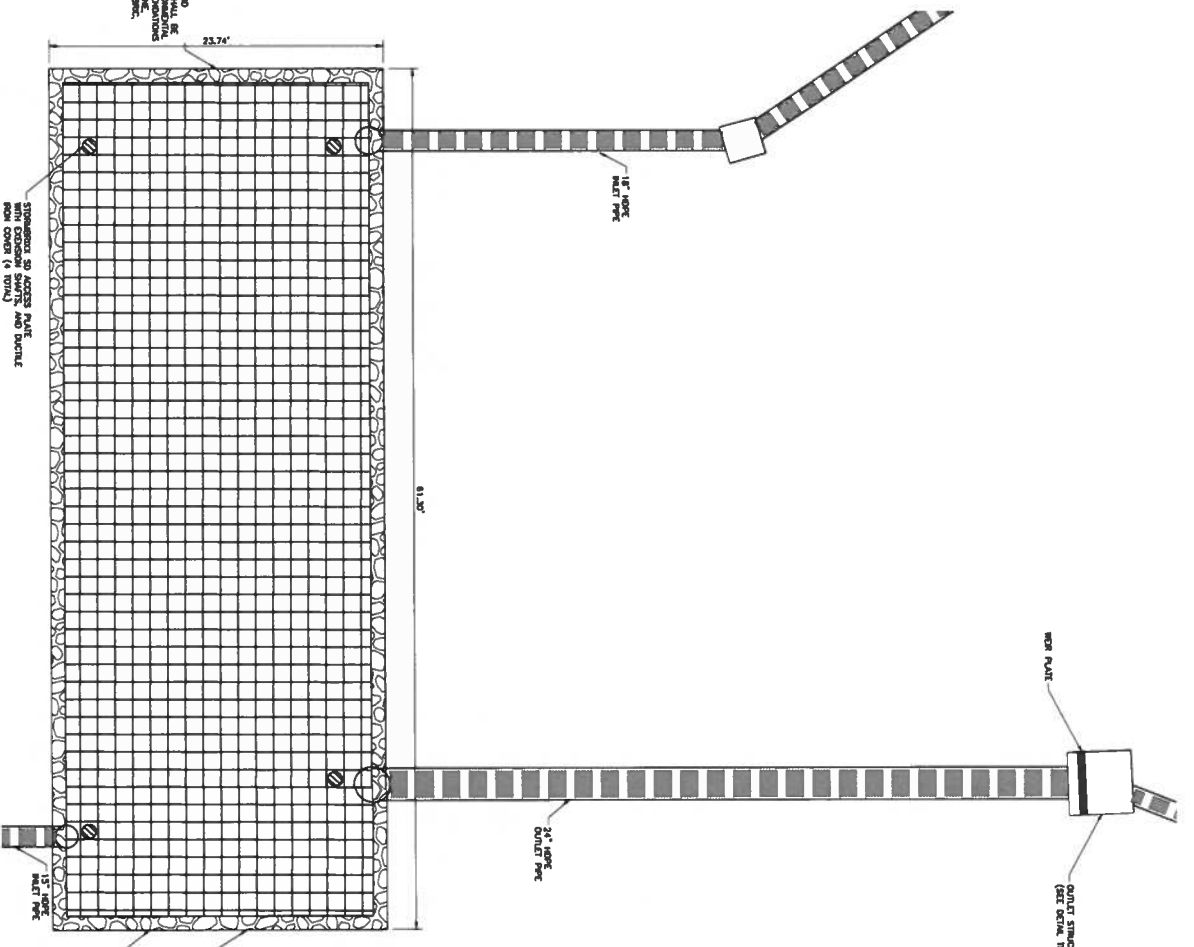

BMP-1 (ACO STORMWATER SD TANK - 1.5 LAYERS) PLAN VIEW

DETAIL A12

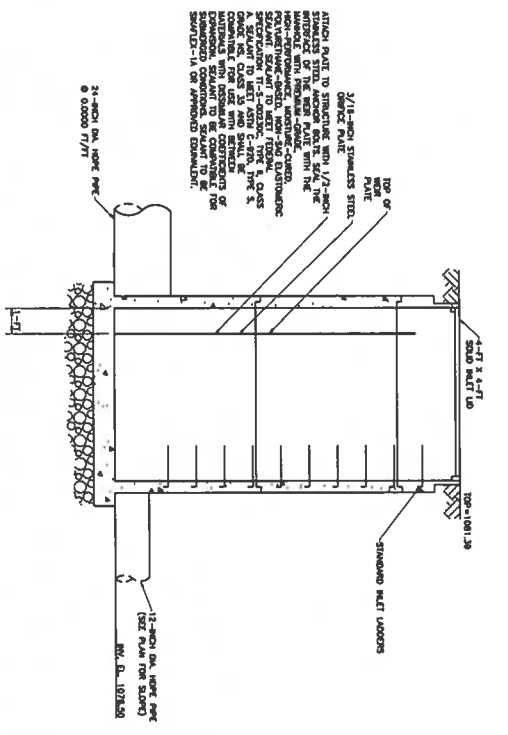

BMP-1 (ACO STORMWATER SD TANK - 1.5 LAYERS)

OUTLET STRUCTURE

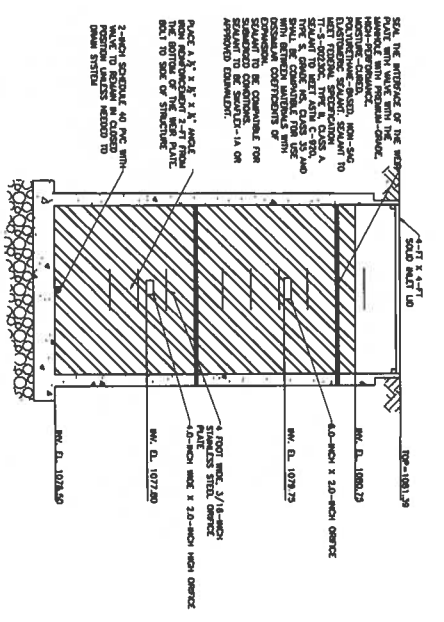

NO.	DATE	DESCRIPTION
02/23/2024	REVISED PER PRELIMINARY LIP COMMENTS	
02/23/2024	FINAL LAND DEVELOPMENT SUBMISSION	

C&E
Civil & Environmental Consultants, Inc.
4350 Northern Pike - Suite 141 - Monroeville, PA 15146
724-327-5200 - 800-899-3810
www.ceinc.com

DRAW COLLECTIVE
470 Washington Road, Pittsburgh, PA 15228
412.561.7117 www.DRAWcollective.com

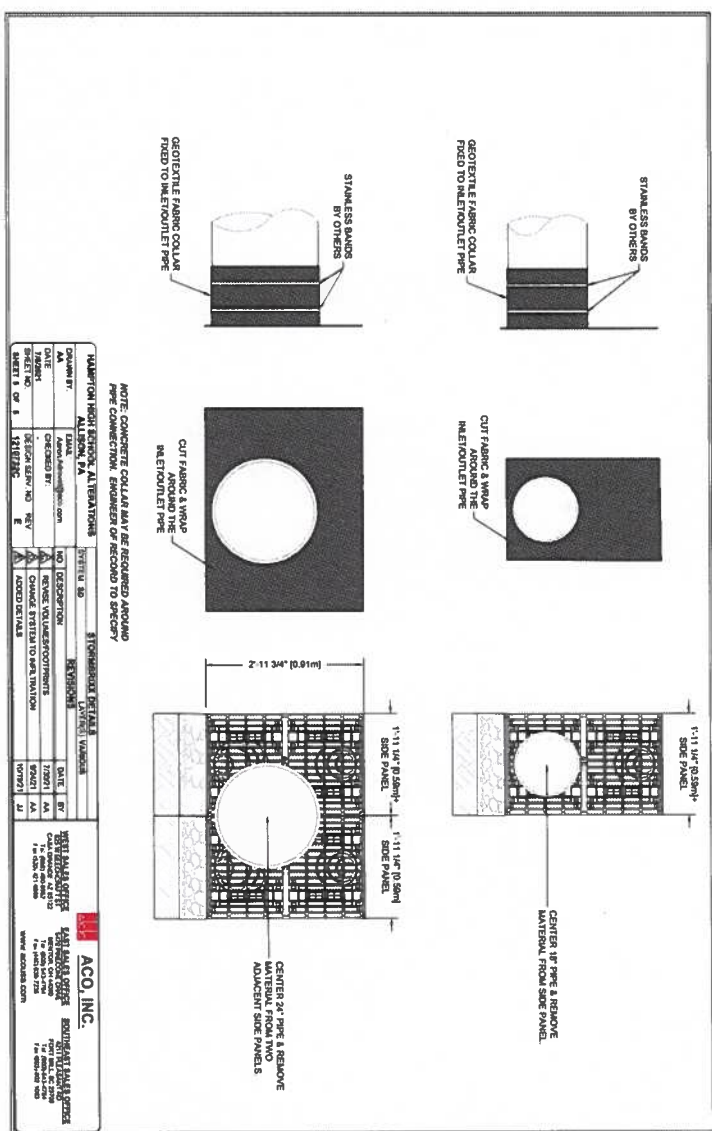
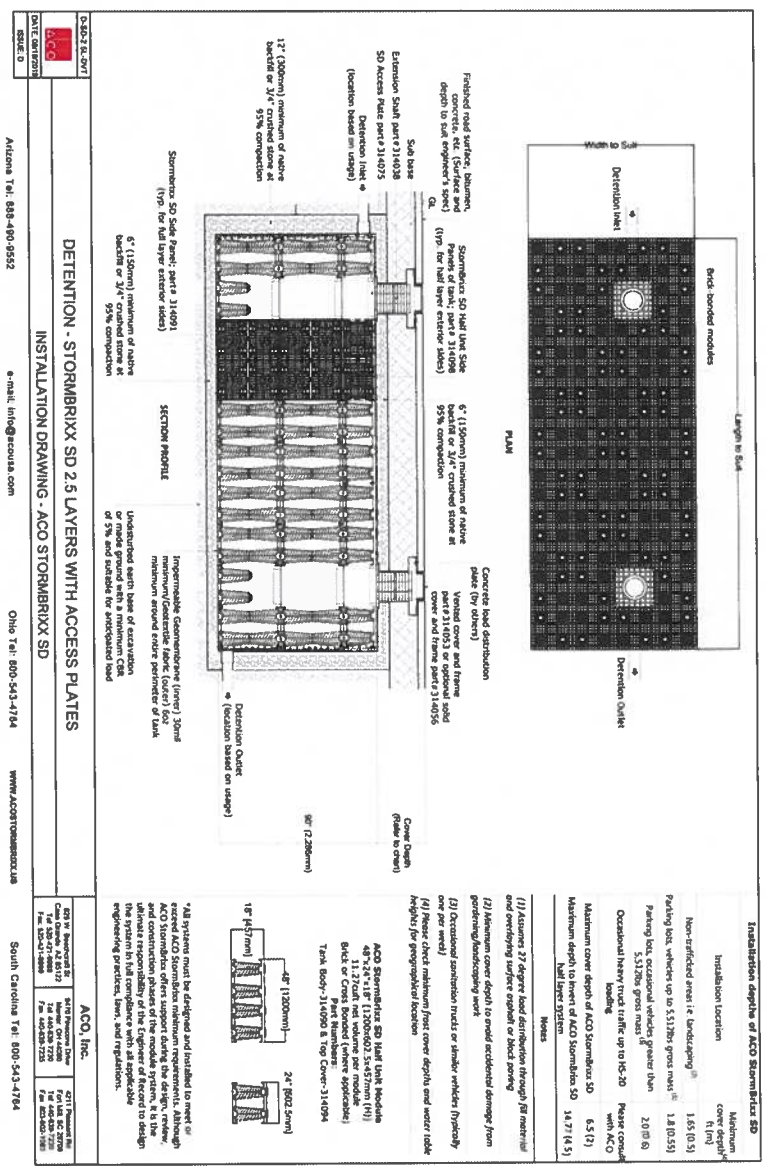
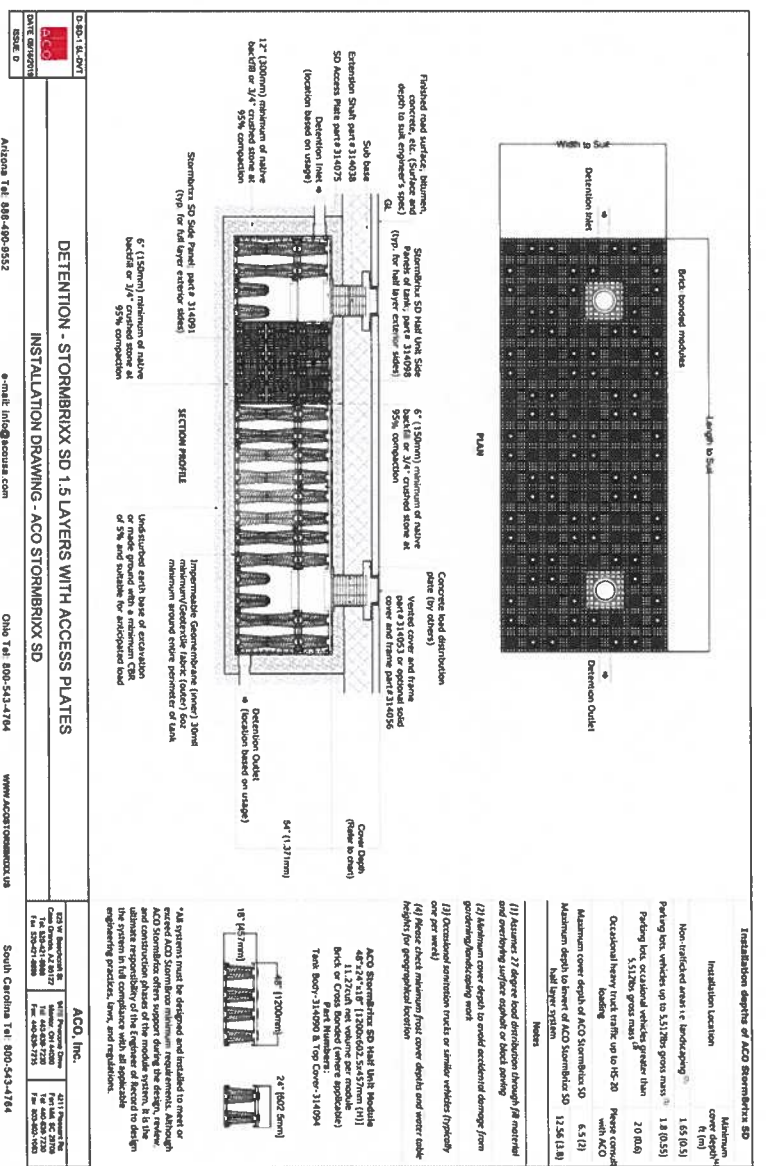

ACO StormBrix® SD
Stormwater Detention/Infiltration/Retention System
January 2021

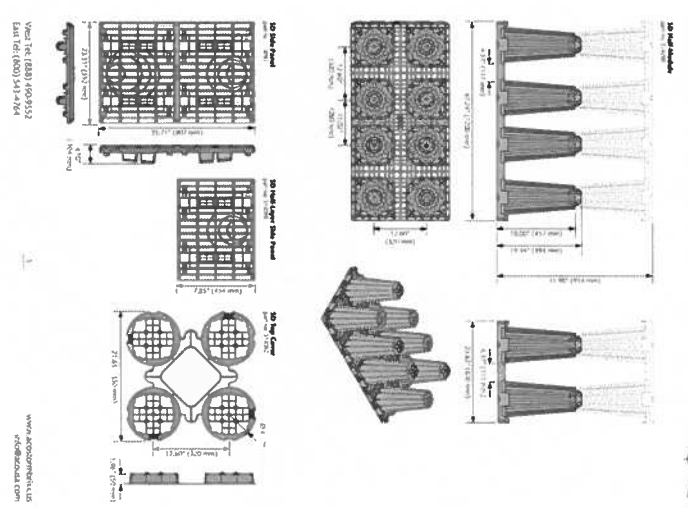

ACO StormBrix® SD
Stormwater Detention/Infiltration/Retention System
January 2021

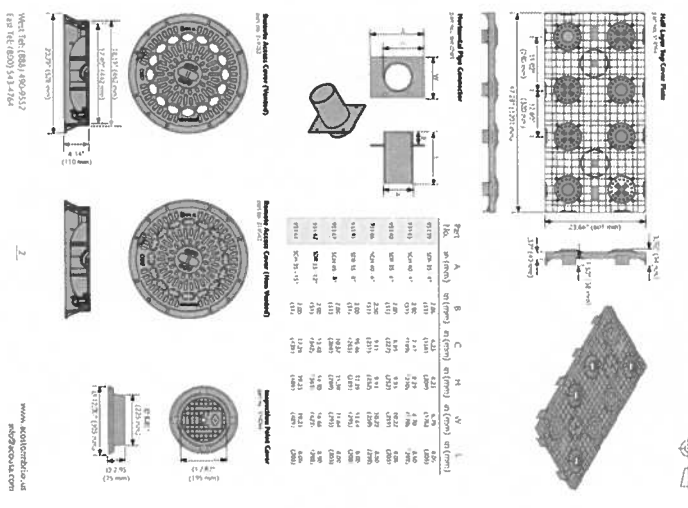

ACO StormBrix® SD
Stormwater Detention/Infiltration/Retention System
January 2021

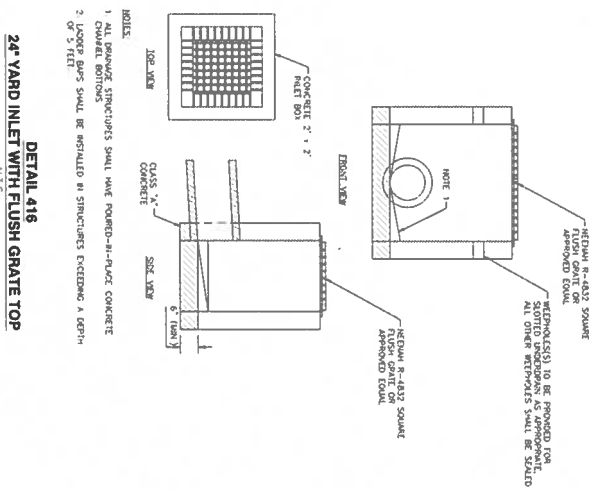
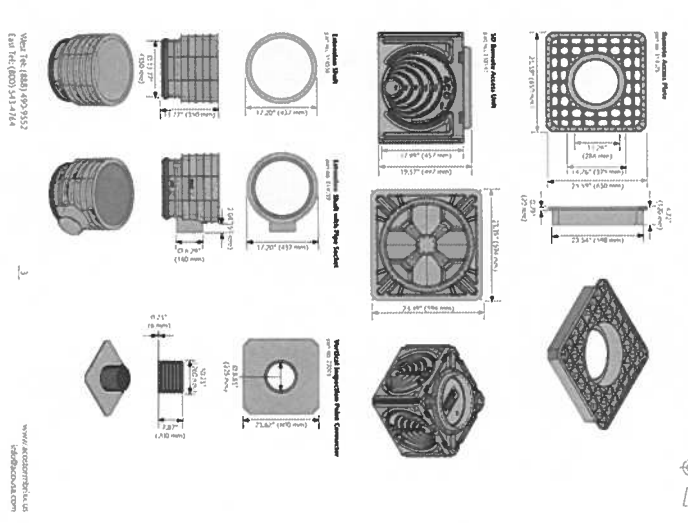

DETAIL 415
STORMBRIX SD STANDARD DETAILS
N.T.S.

